



Vestil Manufacturing Corp.
 2999 North Wayne Street, P.O. Box 507, Angola, IN 46703
 Telephone: (260) 665-7586 -or- Toll Free (800) 348-0868
 Fax: (260) 665-1339
 Web: www.vestilmfg.com e-mail: info@vestil.com

LL-PMPS-Series Pallet Handlers Instruction Manual



RECEIVING INSTRUCTIONS

After delivery, remove the packaging from the product. Inspect the product closely to determine whether it sustained damage during transport. If damage is discovered, record a complete description of it on the bill of lading. If the product is undamaged, discard the packaging.

NOTE: The end-user is solely responsible for confirming that product design, use, and maintenance comply with laws, regulations, codes, and mandatory standards applied where the product is used.

REPLACEMENT PARTS AND TECHNICAL SERVICE

If you have questions that are not addressed in these instructions and to order replacement parts, labels, and accessories, call (260) 665-7586 and ask for the Service and Parts Department. The department can also be contacted online at http://www.vestilmfg.com/parts_info.htm.

Table of Contents

Signal Words.....	2
Hazards.....	2
Specifications.....	3
Exploded View and Bill of Materials: LL-PMPS-50.....	4
Exploded View and Bill of Materials: LL-PMPS-60.....	5
Exploded View and Bill of Materials: LL-PMPS-72.....	6
*DC Modular Power Unit Exploded View, Manifold Assembly, Circuit Diagram, and Layout Views.....	7, 8, 9
*AC Modular Power Unit Exploded View, Manifold Assembly, Circuit Diagram, and Layout View.....	10, 11, 12
Loading Instructions.....	12
Adjusting the Outriggers.....	12
Exploded View: Autoshifter Foot Pump.....	13
Autoshifter Bill of Materials.....	14
Hydraulic Circuit Diagram: Manual Units (Auto-Shifter Foot Pump).....	14
Operating the Lifter: Manual Units (Autoshifter Foot Pump).....	15
Purging Air from the Pump; Purging Air from the Cylinder.....	15
Troubleshooting: Manual Units (Auto-Shifter Foot Pump).....	16
*Hydraulic Circuit Diagram: Electric Units (Modular Power Unit).....	17
*Operating the Lifter: Electric Units (Modular Power Unit).....	17
*Lowering Solenoid; Velocity fuse; Bleeding Air from the Hydraulic Circuit.....	17, 18
*Battery Charger Operation.....	18
Record of Satisfactory Condition.....	19
Inspections & Maintenance.....	19
Replacement Parts; Troubleshooting Guide: Electric Units (Modular Power Unit).....	20
Labeling Diagram.....	21
Limited Warranty.....	22

NOTE: Figures 10A – 12B are views of the modular power unit. These diagrams only apply to units manufactured before 12-01-2018. Units manufactured on or after 12-01-2018 receive a redesigned modular power unit (MPU GEN2). Diagrams and operating instructions for GEN2 power units are provided in separate MPU-AC/DC manuals.

SIGNAL WORDS

This manual uses SIGNAL WORDS to direct the reader's attention to important safety-related messages. These messages describe uses of the product that could result in personal injury or property damage. Each signal word corresponds to a specific hazard level. The following are definitions of signal words that might appear in this manual.



Identifies a hazardous situation which, if not avoided, WILL result in DEATH or SERIOUS INJURY. Use of this signal word is limited to the most extreme situations.



Identifies a hazardous situation which, if not avoided, COULD result in DEATH or SERIOUS INJURY.



Indicates a hazardous situation which, if not avoided, COULD result in MINOR or MODERATE injury.



Identifies practices likely to result in product/property damage, such as operation that might damage the product.

HAZARDS

Vestil strives to identify all foreseeable hazards associated with the use of its products. However, material handling is dangerous and no manual can address every risk. The most effective way to avoid injury is for the end-user to exercise sound judgment whenever using this product.



If this product is used or maintained improperly serious personal injuries or death might result. ALWAYS use the product properly.

• **Failure to read and understand the entire manual before assembling, using or servicing the product constitutes misuse.**

- Read the manual to refresh your understanding of proper use and maintenance procedures.
- DO NOT attempt to resolve any issue with the product unless you are both authorized to do so and *certain* that it will be safe to use afterwards.
- DO NOT modify the product in any way. Unauthorized modifications might make the lifter unsafe to use and automatically void the *Limited Warranty* on p. 22.
- DO NOT exceed the 4,000 lb. capacity, i.e. do not attempt to lift more than 1,200 lb.
- Inspect the product as directed in *Inspections & Maintenance*. DO NOT use it unless it is in *Satisfactory Condition*. Replace each part that is not in satisfactory condition. DO NOT return the lifter to service until it is fully restored to satisfactory condition. ONLY use manufacturer-approved replacement parts.
- Cycle the forks all the way up and down before using the lifter. Listen for unusual sounds. Watch the forks, carriage, cylinder, and carriage rollers for unusual movement. Remove the unit from service and notify your supervisor & maintenance personnel if you notice anything unusual.
- AVOID contact with pressurized hydraulic oil (leaking from a ruptured hose, for instance). High pressure oil easily punctures skin and can cause gangrene and other serious injuries.
- DO NOT use the lifter unless all machine guards are in place. Examples of machine guards include the expanded metal mast guard and wheel covers.
- This product is NOT a personnel lift. DO NOT use it to lift or transport people.
- DO NOT walk or stand beneath the forks. Keep away from the forks and carriage whenever they are elevated or in motion.
- DO NOT leave the lifter unattended while it is loaded. ALWAYS completely lower the forks until the load is entirely supported by the ground before leaving the lifter unattended.
- ONLY transport loads with the forks no higher than necessary to support the load and avoid obstacles.
- DO NOT continue to push the "UP" button on the hand control if the forks do not respond. Remove the unit from service and report the problem to maintenance personnel.
- Always lift pallets properly. Drive forward until the edge of a pallet contacts the heels of the forks.
- ONLY use this lifter on even, level ground.
- NEVER change the setting of the pressure relief valve.
- ALWAYS carefully watch the pallet handler and the load while lifting and transporting loads.
- DO NOT use this device UNLESS all labels are in place, undamaged, and easily readable from a reasonable distance. Refer to the *Labeling Diagram* on p. 21, which provides identification numbers and locations of all labeling applied to the lifter.

SPECIFICATIONS

Dimensions, net weight, and capacity information for each model LL-PMPS appears in the following diagrams and table. Net weight figures do not include weights of modular power units. To determine MPU weight, refer to the *Specifications* section of your MPU-GEN2 instruction manual.

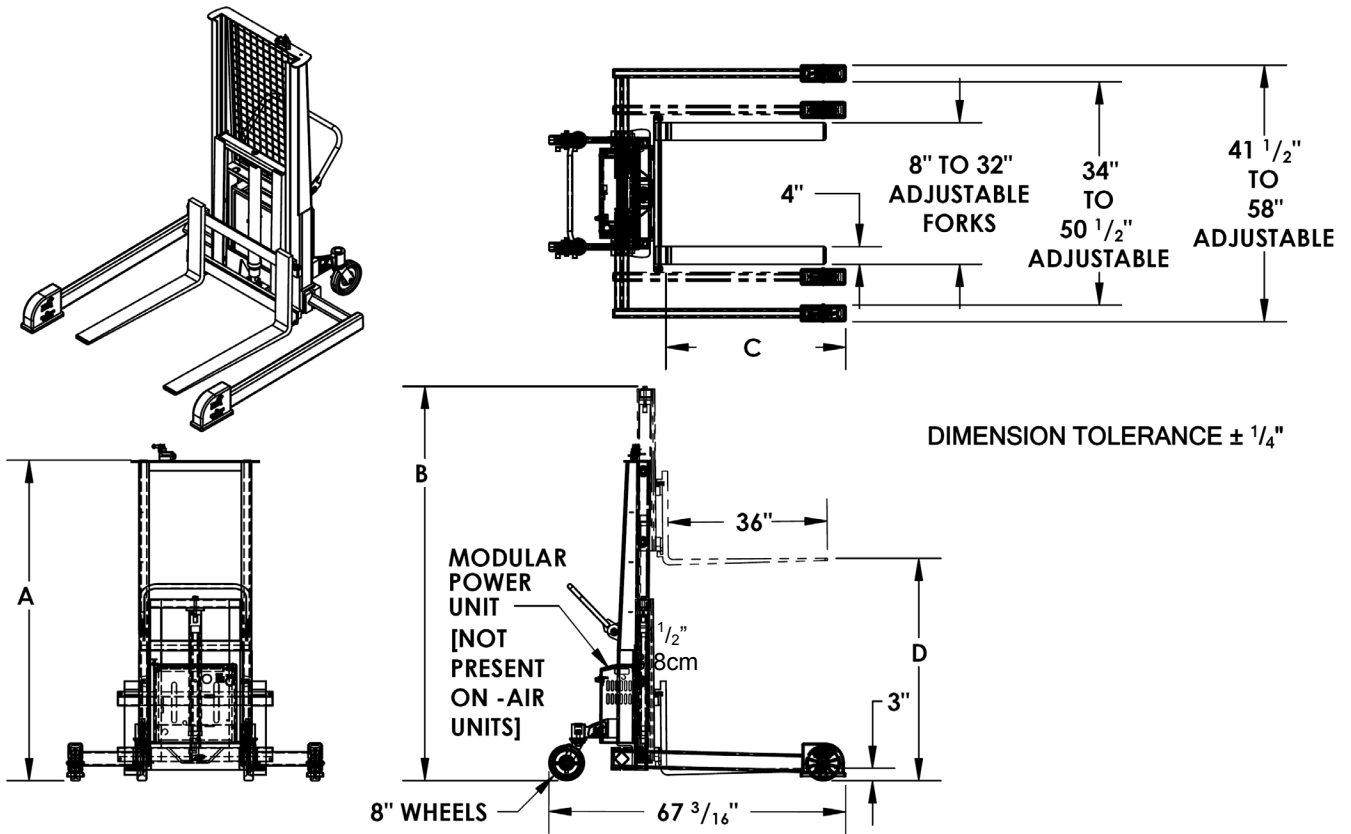

Model	A	B	C	D	Net Weight	Capacity
LL-PMPS-50-AC	72 ¹ / ₂ " 184.2 cm	89" 226.1 cm	40 ¹¹ / ₁₆ " 103.3 cm	50" 127 cm	742 lb. 337.3 kg	1,200 lb. 545.5 kg
LL-PMPS-50-AIR	72 ¹ / ₂ " 184.2 cm	89" 226.1 cm	40 ¹¹ / ₁₆ " 103.3 cm	50" 127 cm	725 lb. 329.5 kg	1,200 lb. 545.5 kg
LL-PMPS-50-DC	72 ¹ / ₂ " 184.2 cm	89" 226.1 cm	40 ¹¹ / ₁₆ " 103.3 cm	50" 127 cm	742 lb. 337.3 kg	1,200 lb. 545.5 kg
LL-PMPS-60-AC	82 ¹ / ₂ " 209.6 cm	103 ³ / ₄ " 263.5 cm	40 ¹¹ / ₁₆ " 103.3 cm	60" 152.4 cm	779 lb. 354.1 kg	1,200 lb. 545.5 kg
LL-PMPS-60-AIR	82 ¹ / ₂ " 209.6 cm	103 ³ / ₄ " 263.5 cm	40 ¹¹ / ₁₆ " 103.3 cm	60" 152.4 cm	779 lb. 354.1 kg	1,200 lb. 545.5 kg
LL-PMPS-60-DC	82 ¹ / ₂ " 209.6 cm	103 ³ / ₄ " 263.5 cm	40 ¹¹ / ₁₆ " 103.3 cm	60" 152.4 cm	779 lb. 354.1 kg	1,200 lb. 545.5 kg
LL-PMPS-72-AC	96 ¹ / ₂ " 245.1 cm	125" 317.5 cm	40 ¹ / ₈ " 101.9 cm	72" 182.9 cm	938 lb. 426.4 kg	1,200 lb. 545.5 kg
LL-PMPS-72-AIR	96 ¹ / ₂ " 245.1 cm	125" 317.5 cm	40 ¹ / ₈ " 101.9 cm	72" 182.9 cm	938 lb. 426.4 kg	1,200 lb. 545.5 kg
LL-PMPS-72-DC	96 ¹ / ₂ " 245.1 cm	125" 317.5 cm	40 ¹ / ₈ " 101.9 cm	72" 182.9 cm	938 lb. 426.4 kg	1,200 lb. 545.5 kg

EXPLODED VIEW AND BILL OF MATERIALS: LL-PMPS-50

38-006-008

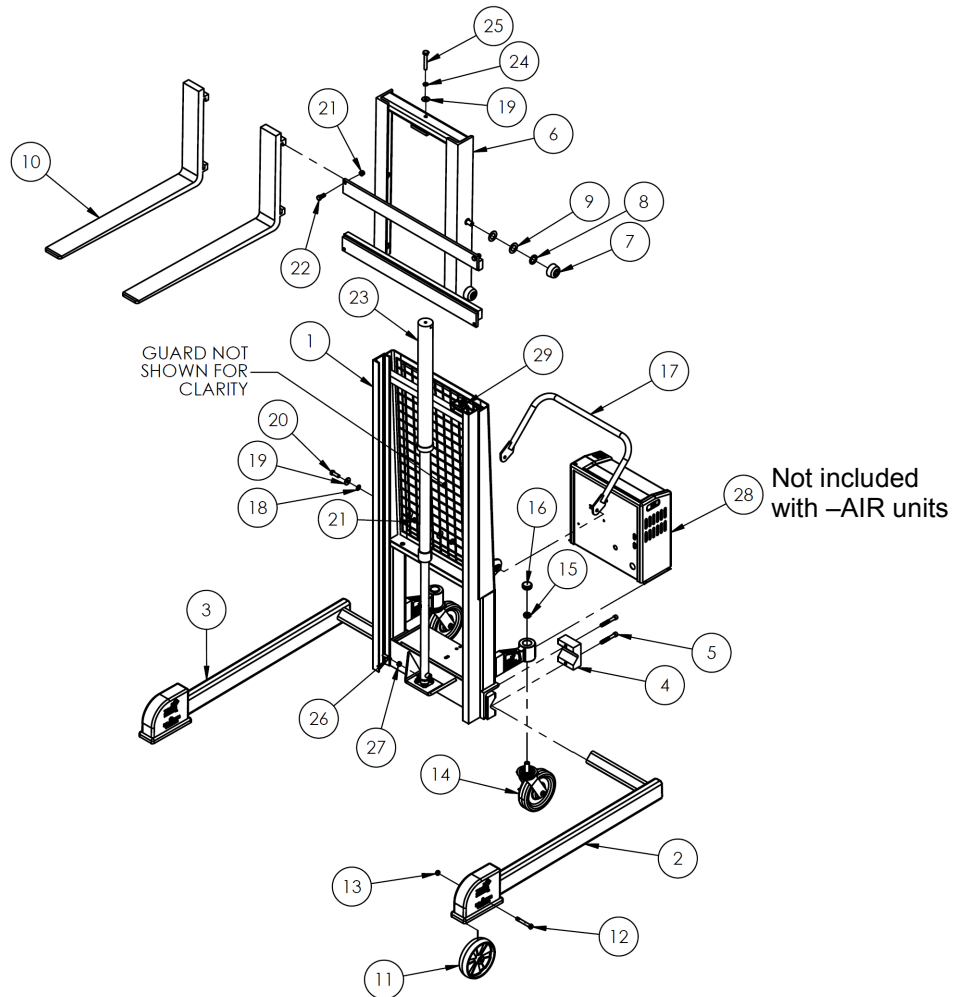

Item	Part no.	Description	Qty.	Item	Part no.	Description	Qty.
1	38-514-011	Frame, weldment	1	16	99-024-003	Plug, non-threaded, plastic, round 1 3/4" outer diameter	2
2	15-514-078	Frame, weldment, left leg	1	17	15-525-007	Handle, weldment	1
3	15-514-079	Frame, weldment, right leg	1	18	33354	1/2" inner diameter Belleville spring washer	4
4	38-016-014	Bracket, non-threaded leg clamp	2	19	33012	1/2" zinc-plated USS flat washer	4
5	23416	Hex socket head cap screw, black oxide, 1/2" - 13 x 3 1/4"	4	20	11209	1/2" - 13 x 1 1/2" HHCS #2 zinc-plated bolt	2
6	38-538-001	Weldment, frame, carriage	1	21	37030	1/2" - 13 lock nut	4
7	21-527-003	Roller assembly, bearing	4	22	11207	1/2" - 13 x 1 1/4" zinc-plated HHCS #2 bolt	2
8	33456	1 1/8" inner diameter 10ga. machine bushing	4	23	99-021-912-001	Cylinder, hydraulic, telescoping, 1 1/2"x48"	1
9	01-115-001	Thrust washer, 1 1/8" inner diameter	8	24	33625	1/2" lock washer	1
10	38-028-007	4" x 36" fork	2	25	12217	1/2" - 13 x 3 1/2" HHCS #5 bolt	1
11	16-132-216	Caster/wheel, GFN-8/2-W	2	26	01-118-001	Bolt, cylinder retaining	1
12	16-145-031	Bolt w/ grease zerk, 1/2" - 13 x 3 1/2"	2	27	36209	1/2" - 13 hex jam nut	1
13	37032	1/2" nylon insert jam nut	2	*28	99-160-001 99-160-040	Modular power unit AC, 115V, 1-phase DC, 12V	1 1
14	16-132-204	Stem caster, PH-8/2-RB-S-SB	2	29	01-022-001	Limit switch with roller arm	1
15	37039	Nylock nut, zinc-plated, 3/4"-10	2				

*Units built after Dec. 1, 2018, receive 2nd generation modular power units (MPU-GEN2).

EXPLODED PARTS DIAGRAM AND BILL OF MATERIALS: LL-PMPS-60

38-006-008

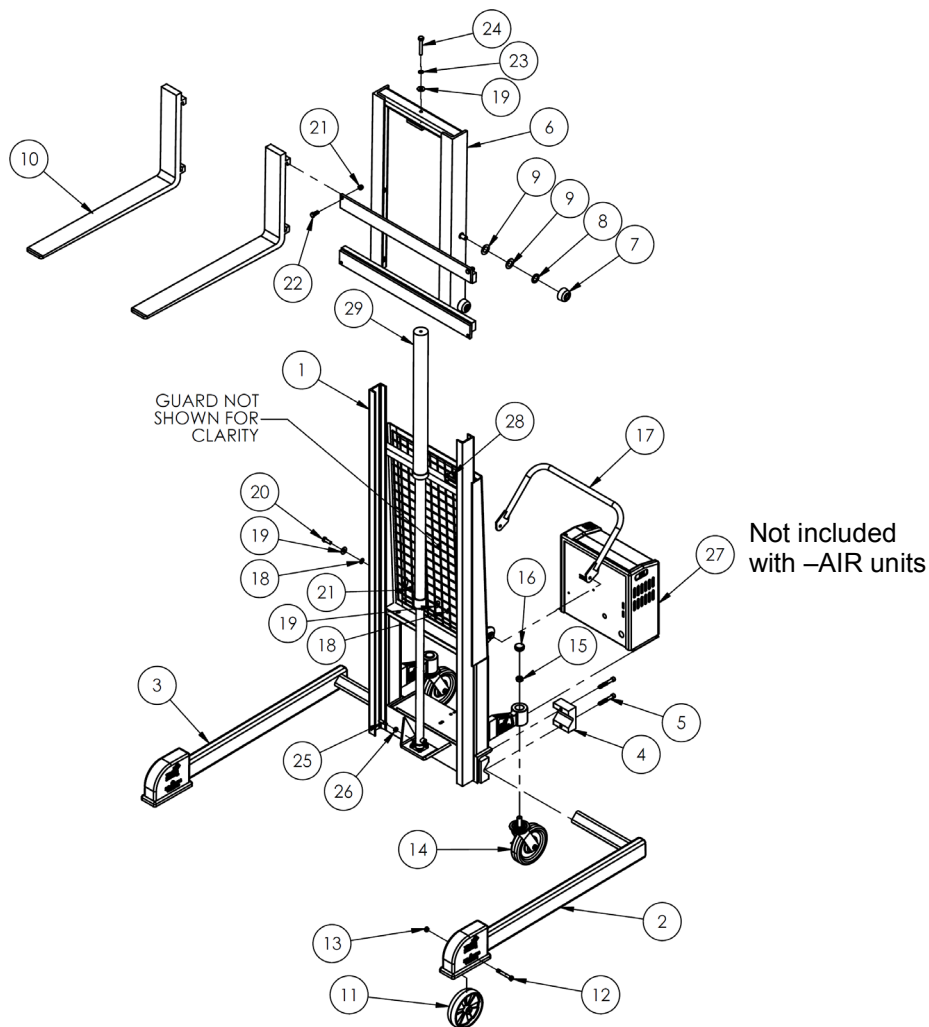

Item	Part no.	Description	Qty.	Item	Part no.	Description	Qty.
1	38-514-012	Frame, weldment	1	16	99-024-003	Plug, non-threaded, plastic, round 1 3/4" outer diameter	2
2	15-514-078	Frame, weldment, left leg	1	17	15-525-007	Handle, weldment	1
3	15-514-079	Frame, weldment, right leg	1	18	33354	1/2" inner diameter Belleville spring washer	4
4	38-016-014	Bracket, non-threaded leg clamp	2	19	33012	1/2" zinc-plated USS flat washer	4
5	23416	Hex socket head cap screw, black oxide, 1/2" - 13 x 3 1/4"	4	20	11209	1/2" - 13 x 1 1/2" HHCS #2 zinc-plated bolt	2
6	38-538-002	Weldment, frame, carriage	1	21	37030	1/2" - 13 lock nut	4
7	21-527-003	Roller assembly, bearing	4	22	11207	1/2" - 13 x 1 1/4" zinc-plated HHCS #2 bolt	2
8	33456	1 1/8" inner diameter 10ga. machine bushing	4	23	33625	1/2" lock washer	1
9	01-115-001	Thrust washer, 1 1/8" inner diameter	8	24	12217	1/2" - 13 x 3 1/2" HHCS #5 bolt	1
10	38-028-007	4" x 36" fork	2	25	01-118-001	Bolt, cylinder retaining	1
11	16-132-216	Caster/wheel	2	26	36209	1/2" - 13 hex jam nut	1
12	16-145-031	Bolt w/ grease zerk, 1/2" - 13 x 3 1/2"	2	*27	99-160-001 99-160-040	Modular power unit AC, 115V, 1-phase DC, 12V	1 1
13	37032	1/2" nylon insert jam nut	2	28	01-022-001	Limit switch with roller arm	1
14	16-132-204	Stem caster, PH-8/2-RB-S-SB	2	29	99-021-913-001	Telescopic cylinder (60)	1
15	37039	Nylock nut, zinc-plated, 3/4"-10	2	*Units built after Dec. 1, 2018, receive 2 nd generation modular power units (MPU-GEN2).			

EXPLODED PARTS DIAGRAM AND BILL OF MATERIALS: LL-PMPS-72

38-006-015

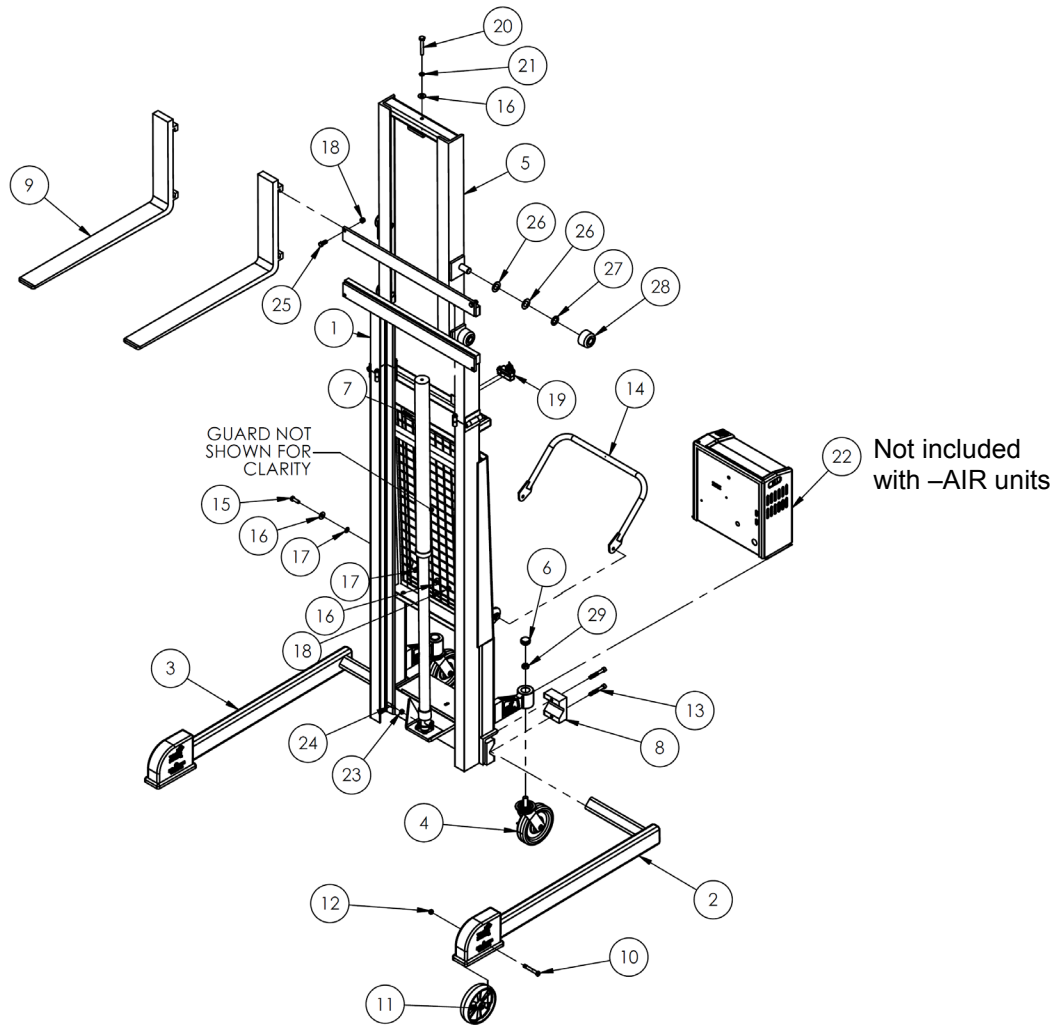

Item	Part no.	Description	Qty.	Item	Part no.	Description	Qty.
1	38-514-042	Frame, weldment	1	16	33012	1/2" zinc-plated USS flat washer	4
2	15-514-078	Frame, weldment, left leg	1	17	33354	1/2" inner diameter Belleville spring washer	4
3	15-514-079	Frame, weldment, right leg	1	18	37030	1/2" - 13 lock nut	4
4	16-132-204	Stem caster, PH-8/2-RB-S-SB	2	19	01-022-001	Limit switch with roller arm	1
5	38-538-006	Weldment, frame, carriage	1	20	12217	1/2" - 13 x 3 1/2" HHCS #5 bolt	1
6	99-024-003	Plug, non-threaded, plastic, round 1 3/4" outer diameter	2	21	33625	1/2" lock washer	1
7	99-021-917-001	Cylinder, hydraulic, telescopic, 1 1/2"x72"	1	*22	99-160-001 99-160-040	Modular power unit AC, 115V, 1-phase DC, 12V	1 1
8	38-016-014	Bracket, non-threaded leg clamp	2	23	36209	1/2" - 13 hex jam nut	1
9	38-028-007	4" x 36" fork	2	24	01-118-001	Bolt, cylinder retaining	1
10	16-145-031	Bolt with grease zerk, 1/2" - 13 x 3 1/2"	2	25	11207	1/2" - 13 x 1 1/4" zinc-plated HHCS #2 bolt	2
11	16-132-216	Caster/wheel	2	26	01-115-001	Thrust washer, 1 1/8" inner diameter	8
12	37032	1/2" nylon insert jam nut	2	27	33456	1 1/8" inner diameter 10ga. machine bushing	4
13	23416	Hex socket head cap screw, black oxide, 1/2" - 13 x 3 1/4"	4	28	15-527-004	Roller subassembly	4
14	15-525-007	Handle, weldment	1	29	37039	Nylock nut, zinc-plated, 3/4"-10	2
15	11209	1/2" - 13 x 1 1/2" HHCS #2 zinc-plated bolt	2	*Units built after Dec. 1, 2018, receive 2 nd generation modular power units (MPU-GEN2).			

DC MODULAR POWER UNIT EXPLODED VIEW AND BILL OF MATERIALS

NOTE: THIS DIAGRAM APPLIES TO UNITS BUILT BEFORE DEC. 1, 2018. UNITS MANUFACTURED ON OR AFTER DEC. 1, 2018, RECEIVE 2ND GENERATION MODULAR POWER UNITS (MPU-GEN2). SEPARATE INSTRUCTION MANUALS ARE PROVIDED FOR THESE POWER UNITS.

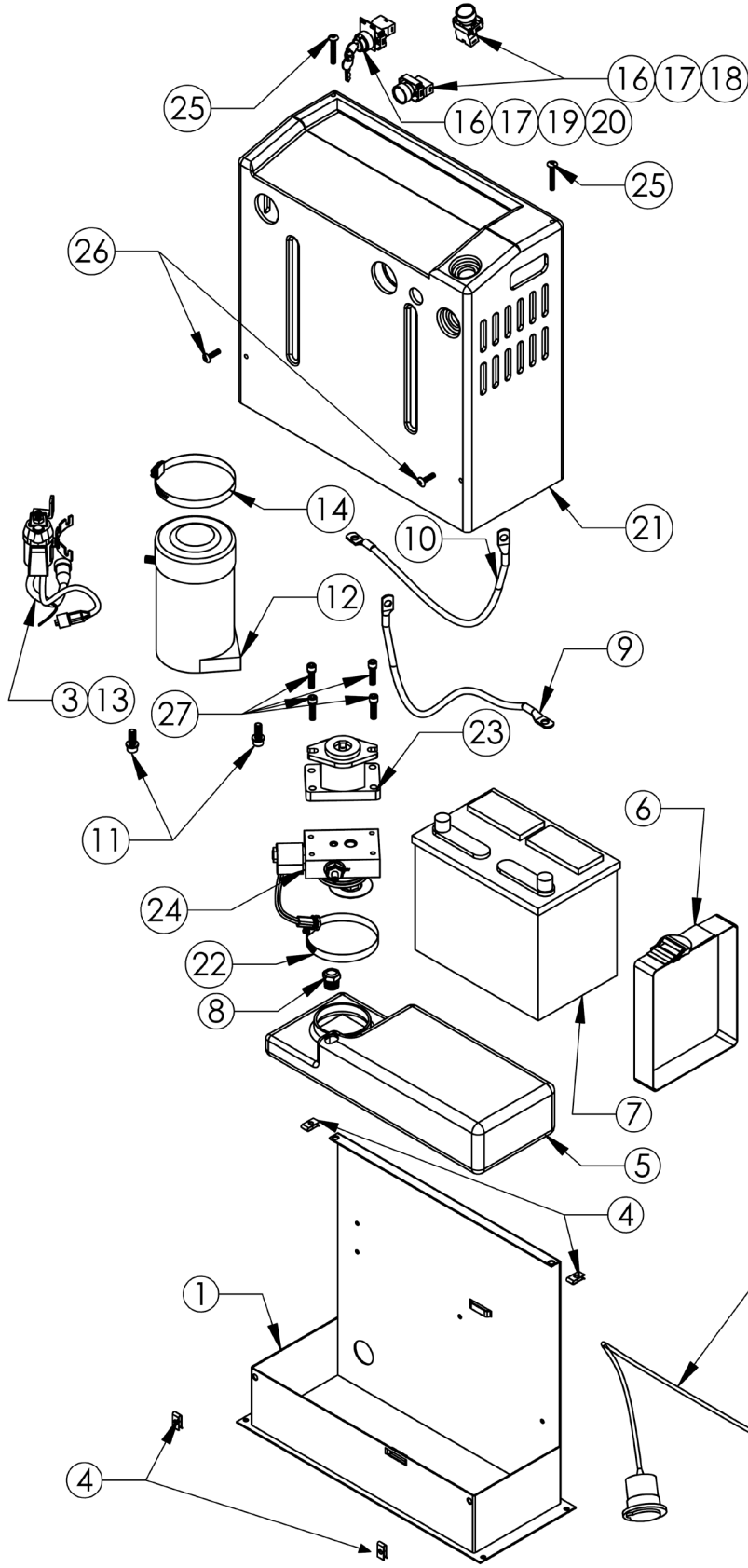

Item	Part no.	Description	Qty.
1	99-016-933	Base bracket	1
2	21-034-008	Charger (Soniel)	1
3	01-033-024	24", 18/3, 4-pin plug	1
4	37927	Tinnerman clip	4
5	99-023-001	Reservoir	1
6	99-034-013	Battery strap	1
7	24DC36	Battery	1
8	BV-48	Breather	1
9	15-533-013	Cable, battery, 23" black	1
10	15-533-014	Cable, battery, 23" red	1
11	23305 33688 33008	³ / ₈ " - 16 x 1" utility grade bolt ³ / ₈ " high collar lock washer ³ / ₈ " flat washer	2 2 2
12	99-135-011	4", 12VDC motor w/ tang dr.	1
13	15-022-004	12V start solenoid relay	1
14	HS64	Worm gear hose clamp	1
15	BG-12V	Battery gauge	1
16	ZB2BZ009	Base, contact block	3
17	ZB2BE101	Contact block N.O.	3
18	ZB2BA2C	Operator, black, non-illuminated	2
19	ZB2BG4C	Key switch, 2-position	1
20	01-134-007	Legend, ON - OFF	1
21	091802JY	Fiberglass cover	1
22	HS52	Clamp, worm gear	1
23	01-143-906	Pump	1
24	01-627-010	Manifold assembly (exploded view on p. 12)	1
25	29201	¹ / ₄ in. - 20 x 1 ¹ / ₄ in. TPHMS zinc-plated	2
26	29185	¹ / ₄ in. - 20 x 1in. TPHMS zinc-plated	2
27	23255 33687	SHCS utility grade High collar lock washer	4 4
28	152400-03	Molded cord	1
29	150CCTM.OEM	Connector, charge	1
30	3MT ST3540	1in. hook and loop press	10"

EXPLODED VIEW OF DC MANIFOLD ASSEMBLY (ITEM NO. 24 ON P. 7)

NOTE: THIS DIAGRAM APPLIES T UNITS BUILT BEFORE DEC. 1, 2018. UNITS MANUFACTURED ON OR AFTER DEC. 1, 2018, RECEIVE 2ND GENERATION MODULAR POWER UNITS (MPU-GEN2). SEPARATE INSTRUCTION MANUALS ARE PROVIDED FOR THESE POWER UNITS.

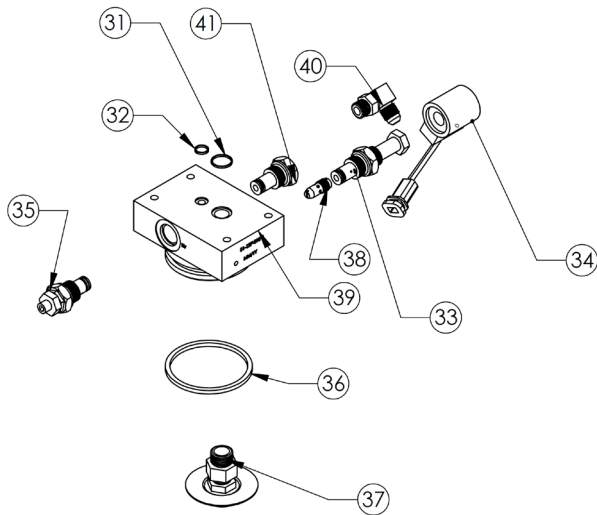

Item	Part no.	Description	Quantity
31	568-015-BN70	O-ring	1
32	568-011-BN70	O-ring	1
33	99-153-015	Valve, cartridge, normally closed	1
34	99-034-010	Coil with weather-tite plug	1
35	99-153-006	Valve, pressure relief	1
36	568-334-BN70	O-ring	1
37	99-531-005	Filter	1
38	99-153-038	Flow control, 1.0GPM	1
39	01-127-010	Manifold	1
40	6801-06-06-NWO	MJ-MAORB 90 degree	1
41	99-153-011	Valve, check	1

12VDC MODULAR POWER UNIT ELECTRICAL CIRCUIT DIAGRAM

NOTE: THIS DIAGRAM APPLIES T UNITS BUILT BEFORE DEC. 1, 2018. UNITS MANUFACTURED ON OR AFTER DEC. 1, 2018, RECEIVE 2ND GENERATION MODULAR POWER UNITS (MPU-GEN2). SEPARATE INSTRUCTION MANUALS ARE PROVIDED FOR THESE POWER UNITS.

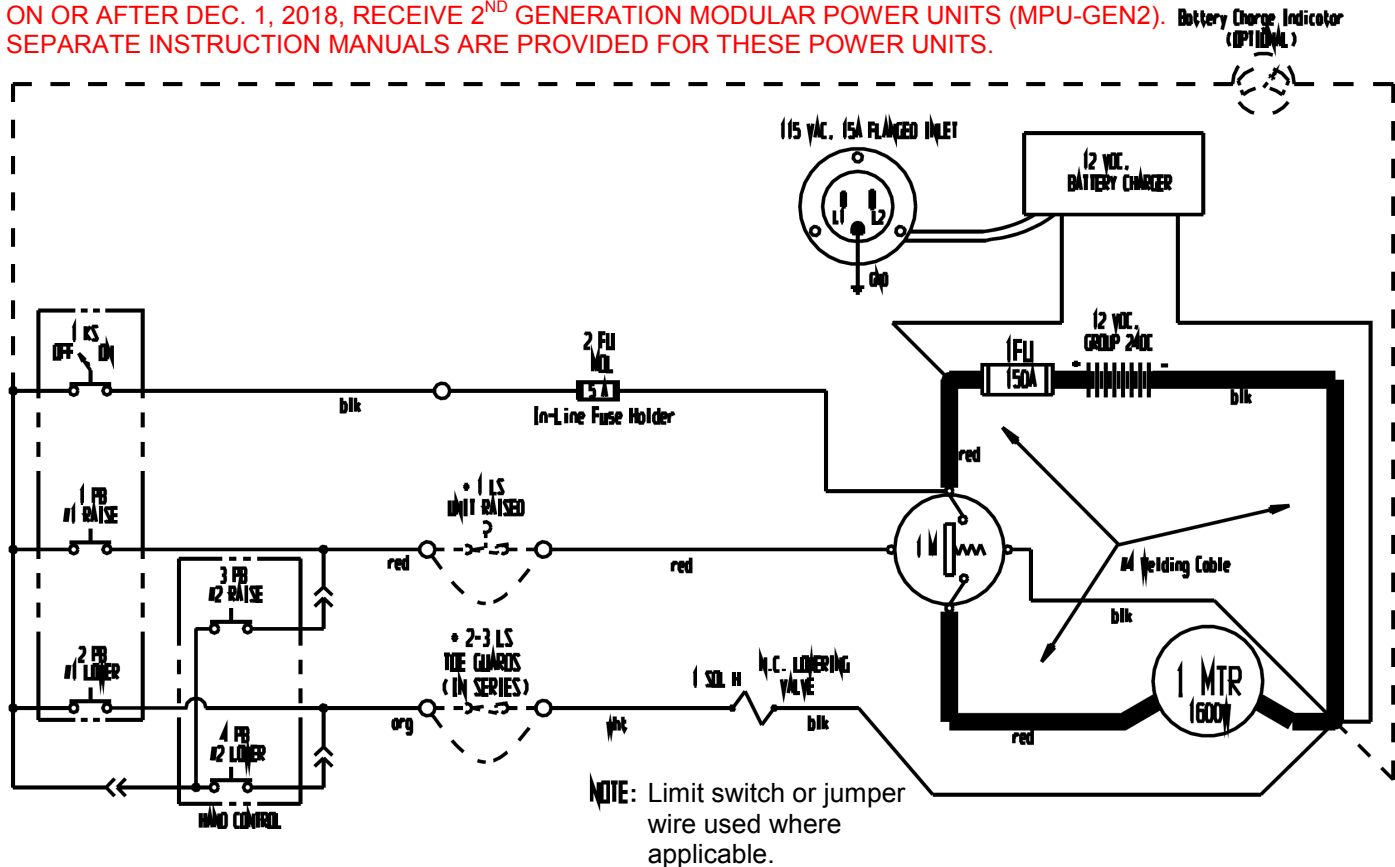

Overcurrent & short-circuit protection as well as system disconnect must be provided by the owner/installer.

12VDC MODULAR POWER UNIT LAYOUT (PART 1 OF 2)

NOTE: THIS DIAGRAM APPLIES TO UNITS BUILT BEFORE DEC. 1, 2018. UNITS MANUFACTURED ON OR AFTER DEC. 1, 2018, RECEIVE 2ND GENERATION MODULAR POWER UNITS (MPU-GEN2). SEPARATE INSTRUCTION MANUALS ARE PROVIDED FOR THESE POWER UNITS.

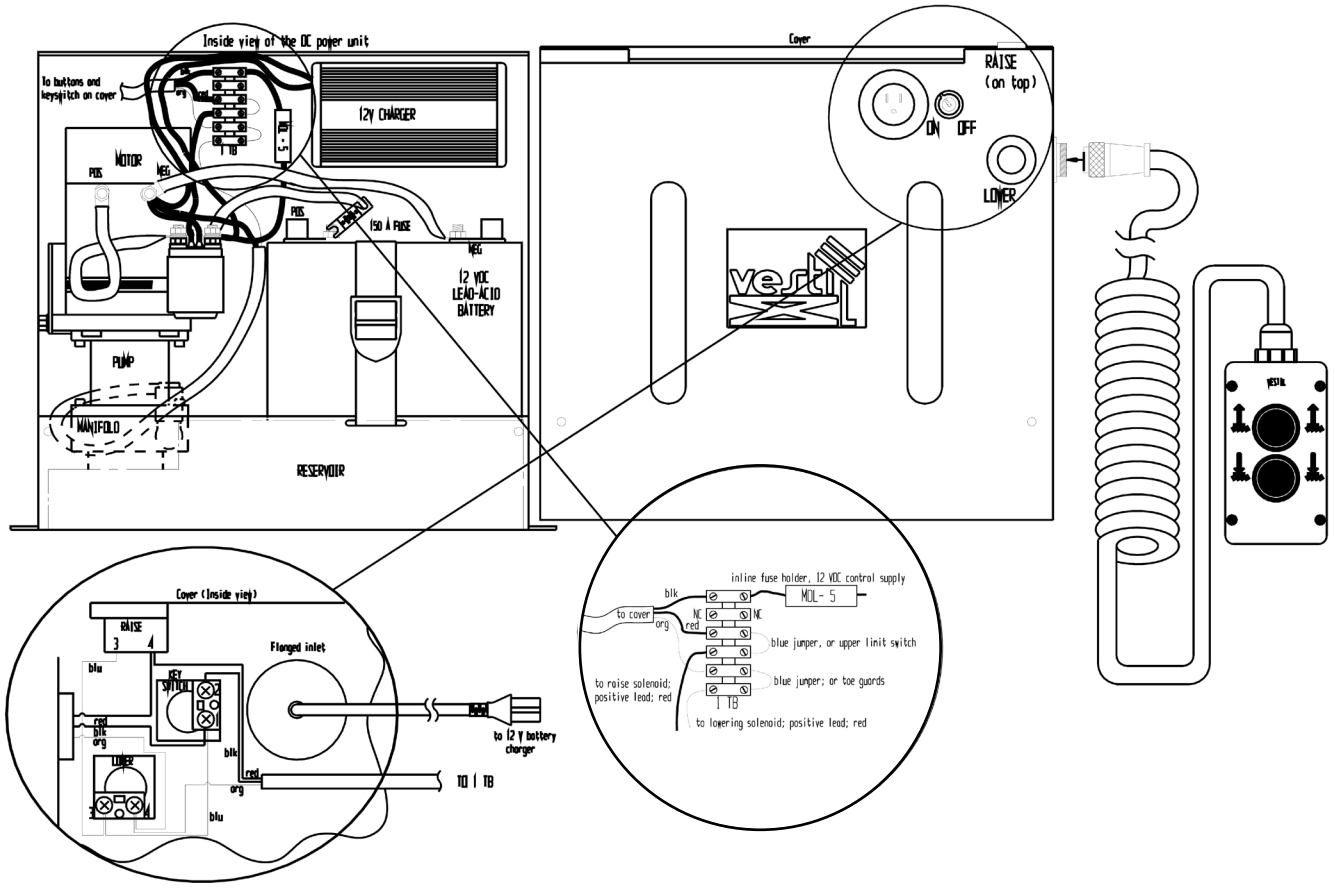

12VDC MODULAR POWER UNIT LAYOUT (PART 2 OF 2)

NOTE: THIS DIAGRAM APPLIES TO UNITS BUILT BEFORE DEC. 1, 2018. UNITS MANUFACTURED ON OR AFTER DEC. 1, 2018, RECEIVE 2ND GENERATION MODULAR POWER UNITS (MPU-GEN2). SEPARATE INSTRUCTION MANUALS ARE PROVIDED FOR THESE POWER UNITS.

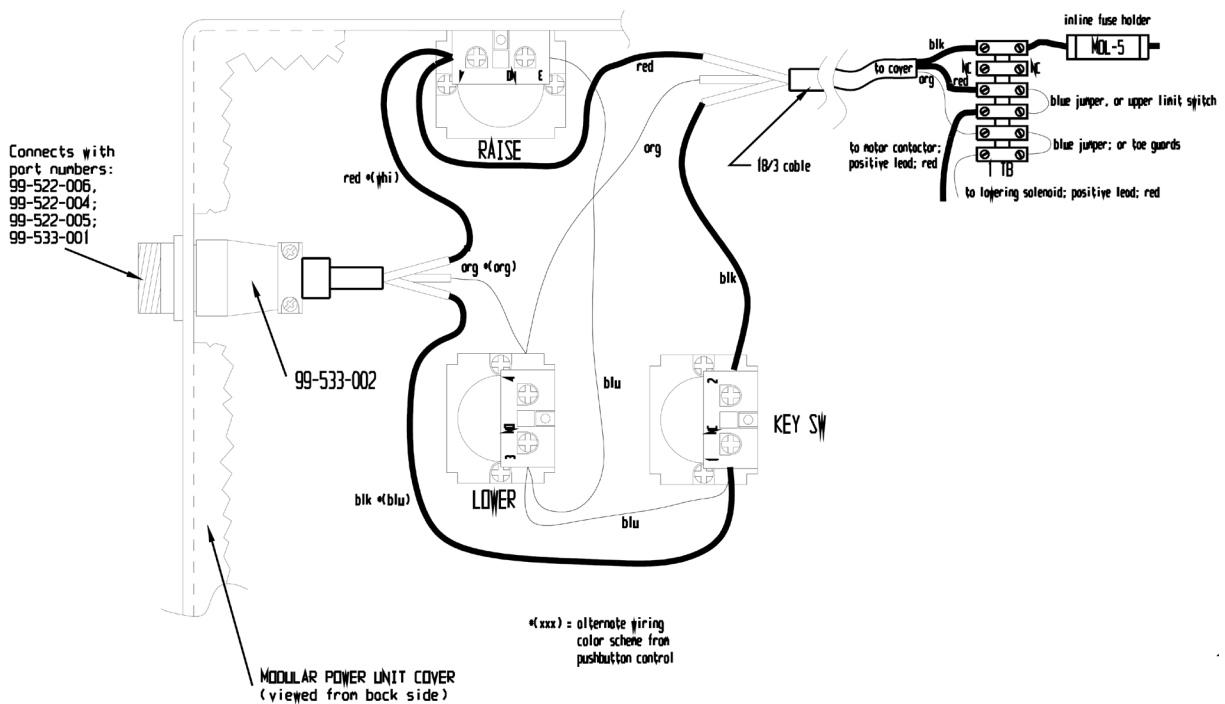

AC MODULAR POWER UNIT EXPLODED PARTS DIAGRAM AND PARTS LIST

NOTE: THIS DIAGRAM APPLIES TO UNITS BUILT BEFORE DEC. 1, 2018. UNITS MANUFACTURED ON OR AFTER DEC. 1, 2018, RECEIVE 2ND GENERATION MODULAR POWER UNITS (MPU-GEN2). SEPARATE INSTRUCTION MANUALS ARE PROVIDED FOR THESE POWER UNITS.

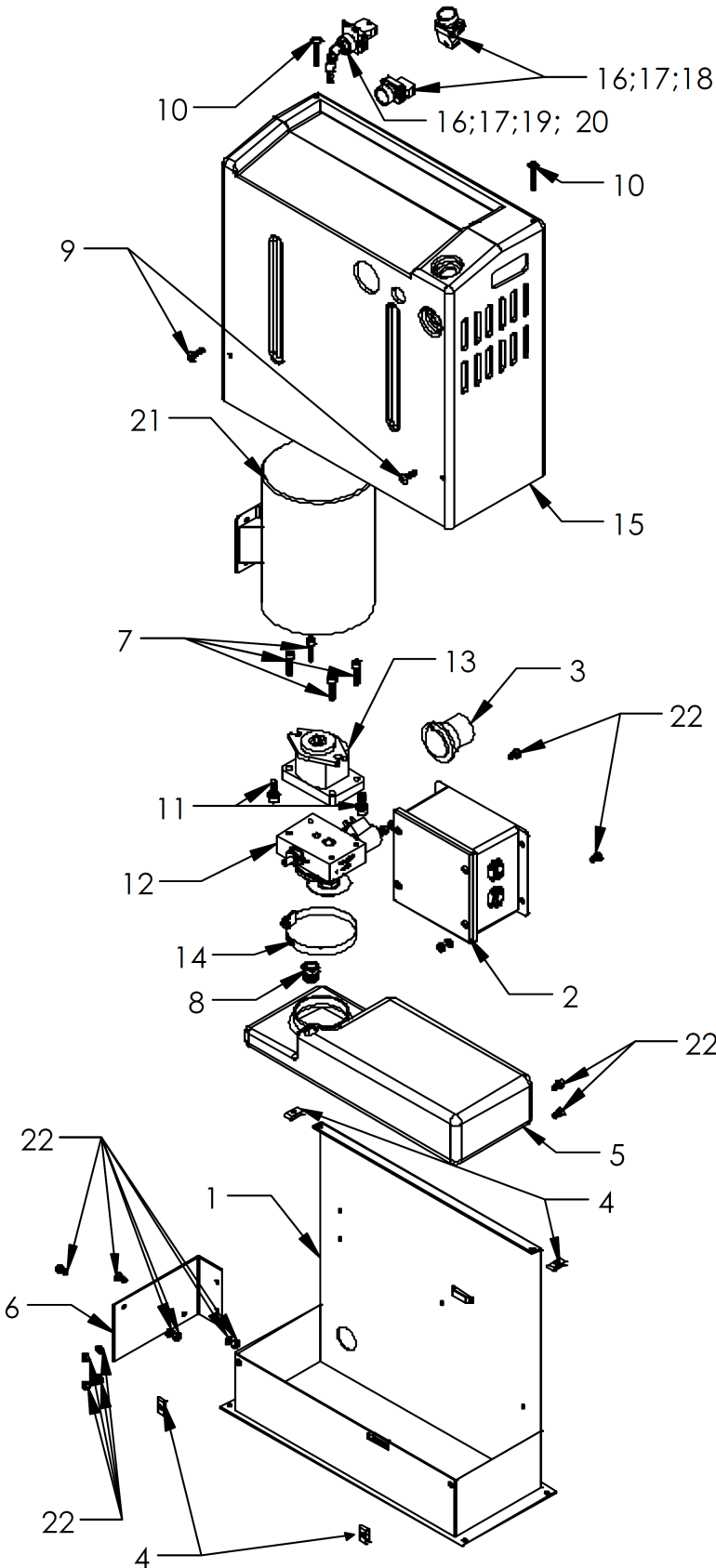

Item	Part no.	Description	Quantity
1	99-016-933	Base bracket	1
2	21-034-008	Electrical box (see FIG. 6B)	1
3	21-034-005	AC adaptor plug	1
4	37927	Tinnerman clip	4
5	99-023-001	Reservoir	1
6		Motor brace	1
7	23255 33687	$\frac{5}{16}$ " - 18 x 1" utility grade bolt $\frac{5}{16}$ " high collar lock washer	4 4
8	BV-48	Breather	1
9	29185	$\frac{1}{4}$ " - 20 x 1" TPHMS z-plated screw	1
10	29201	$\frac{1}{4}$ " - 20 x 1 $\frac{3}{4}$ " TPHMS z-plated screw	1
11	23305 33688 33008	$\frac{3}{8}$ " - 16 x 1" utility grade bolt $\frac{3}{8}$ " high collar lock washer $\frac{3}{8}$ " flat washer	2 2 2
12	01-627-010	Manifold (see FIG. 6C)	1
13	01-143-906	Pump	1
14	HS52	Worm gear hose clamp	1
15	091802JY	Fiberglass cover	1
16	ZB2BZ009	Base, contact block	3
17	ZB2BE101	Contact block N.O.	3
18	ZB2BA2C	Operator, black, non-illuminated	2
19	ZB2BG4C	Key switch, 2-position	1
20	01-134-007	Legend, ON - OFF	1
21		Motor	1
22	HS52	Clamp, worm gear	1
23	01-143-906	Pump	1
24	01-627-010	Manifold assembly (exploded view on p. 12)	1
25	29201	$\frac{1}{4}$ in. - 20 x 1 $\frac{3}{4}$ in. TPHMS zinc-plated	2
26	29185	$\frac{1}{4}$ in. - 20 x 1in. TPHMS zinc-plated	2
27	23255 33687	SHCS utility grade High collar lock washer	4 4
28	152400-03	Molded cord	1
29	150CCTM.OEM	Connector, charge	1
30	3MT ST3540	1in. hook and loop press	10"

ELECTRICAL BOX (ITEM NO. 2 ON P. 10)

NOTE: THIS DIAGRAM APPLIES T UNITS BUILT BEFORE DEC. 1, 2018. UNITS MANUFACTURED ON OR AFTER DEC. 1, 2018, RECEIVE 2ND GENERATION MODULAR POWER UNITS (MPU-GEN2). SEPARATE INSTRUCTION MANUALS ARE PROVIDED FOR THESE POWER UNITS.

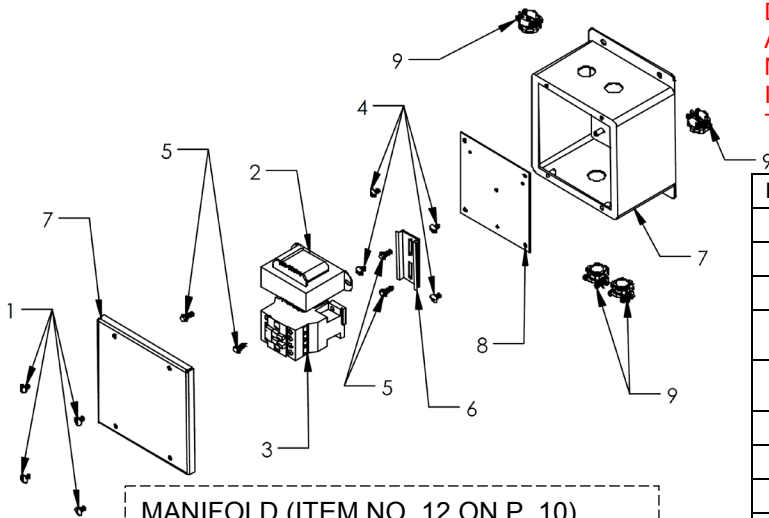

MANIFOLD (ITEM NO. 12 ON P. 10)

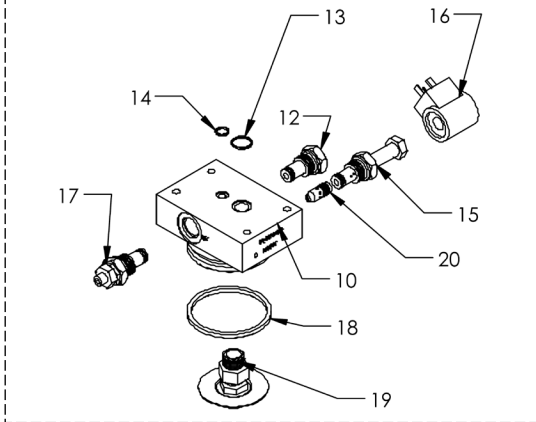

Item	Part no.	Description	Qty.
1	71616	10 – 32 x 5/8" TSHMS screws	4
2	01-129-001	Transformer	1
3	132560	Motor contactor	1
4	27531	10 – 32 x 1/4" PSHMS zinc-plated screws	4
5	32028	8 – 18 x 1/2" HWH TEK drill and tap screws	4
6	99-034-941	Aluminum din rail	3"
7	01-029-006	5/16" – 18 x 1" utility grade bolt	1
8	99-029-142	6" x 6" enclosure plate	1
9	99-034-037	3/8" (1/2" knockout) Romex 2-screw NM clamp connector	4
10	01-127-010	LHL standard manifold, 3" boss	1
11	99-116-033	3/8" – 16 x 1" utility grade bolt	2
12	99-153-011	Check valve	1
13	99-144-023	O-ring	1
14	99-144-022	O-ring	1
15	99-153-015	Normally closed cartridge valve	1
16	99-034-008	24VAC coil	1
17	99-153-006	Pressure relief valve	1
18	99-144-007	O-ring	1
19	99-531-005	Filter	1
20	99-153-038	Flow control, 1.0GPM	1

115VAC MODULAR POWER UNIT ELECTRICAL CIRCUIT DIAGRAM

NOTE: THIS DIAGRAM APPLIES T UNITS BUILT BEFORE DEC. 1, 2018. UNITS MANUFACTURED ON OR AFTER DEC. 1, 2018, RECEIVE 2ND GENERATION MODULAR POWER UNITS (MPU-GEN2). SEPARATE INSTRUCTION MANUALS ARE PROVIDED FOR THESE POWER UNITS.

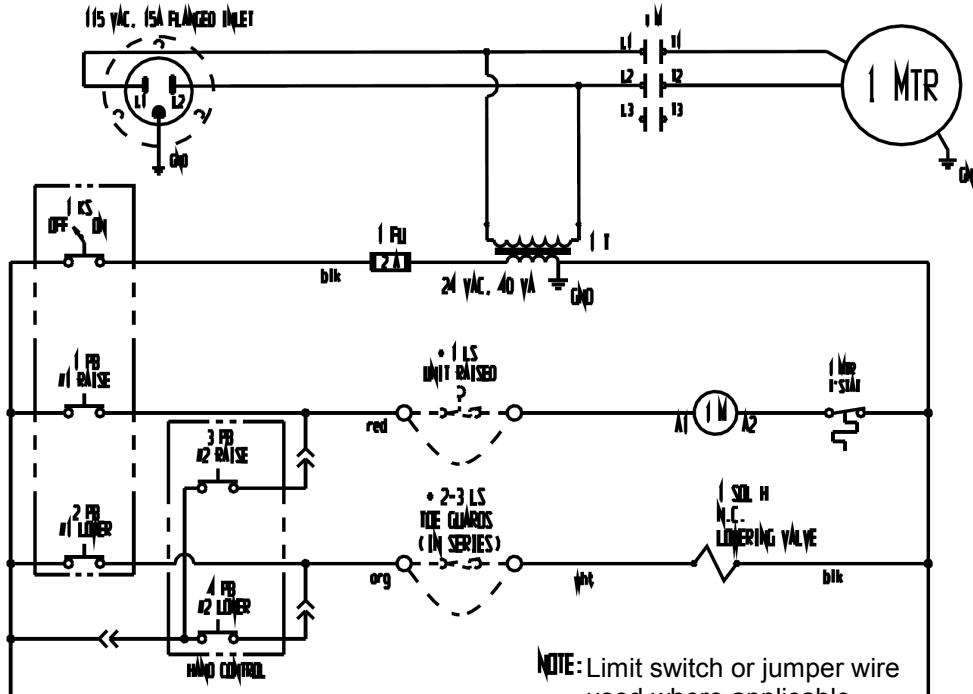

NOTE: Overcurrent & short-circuit protection as well as system disconnect must be provided.

NOTE: Limit switch or jumper wire used where applicable.

MODULAR POWER UNIT LAYOUT: 115VAC

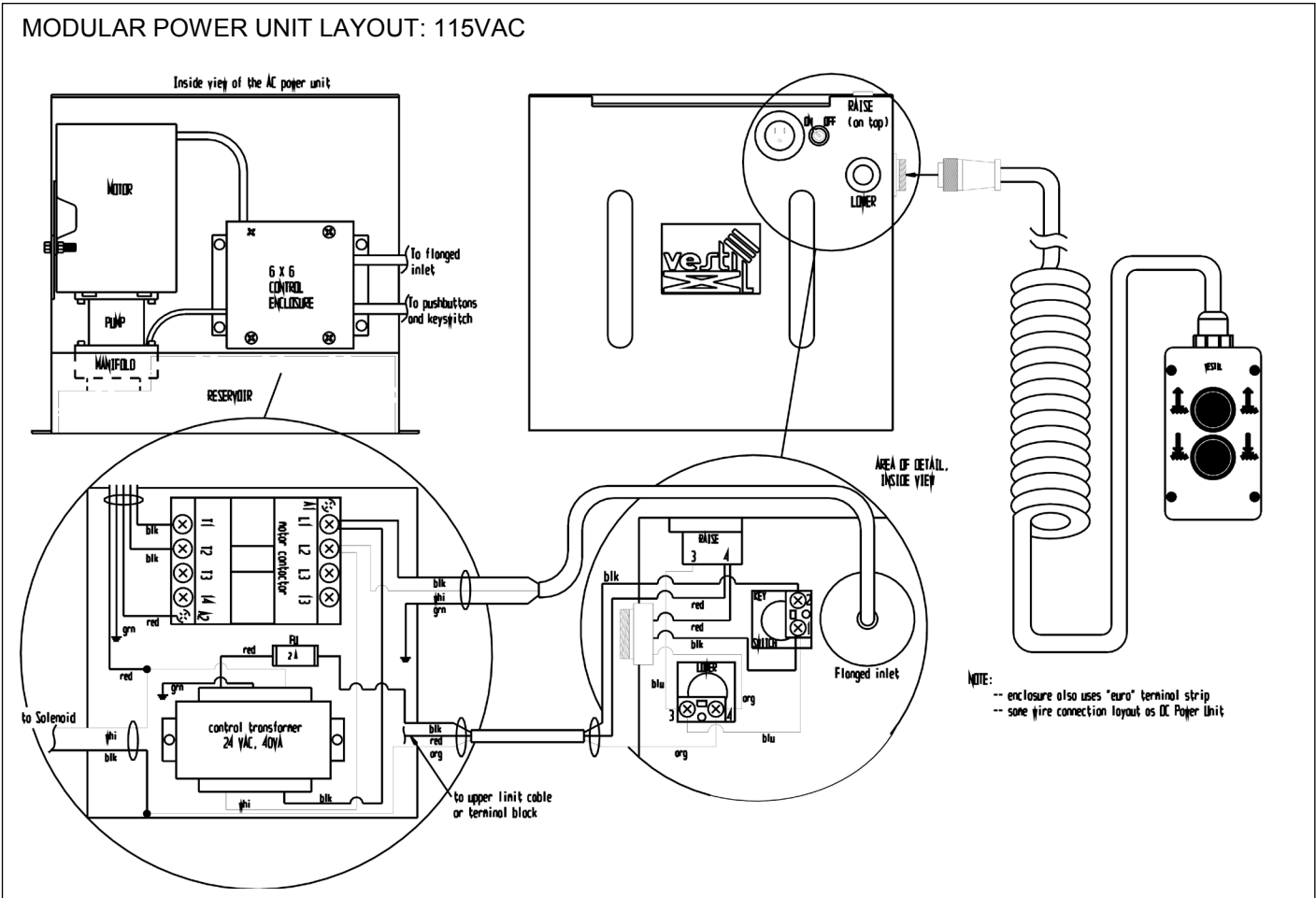

LOADING INSTRUCTIONS

The capacity of this LL-PMPS-series lifter is 1,200 lb. Every unit is labeled with this information (label 287 on p. 21). DO NOT attempt to lift loads that exceed the 1,200 lb. (545.5kg) capacity! Personal injury or permanent damage to the lifter might occur.

When applying a load to the forks, always follow these guidelines:

1. The load should firmly contact the heels of the forks
2. DO NOT apply a load to the tips of the forks
3. Center the load on the forks
4. Only transport loads in the lowered position
5. Apply the caster locks of both rear casters while loading, unloading, and storing the lifter.
6. ONLY use the lifter on level, even ground.

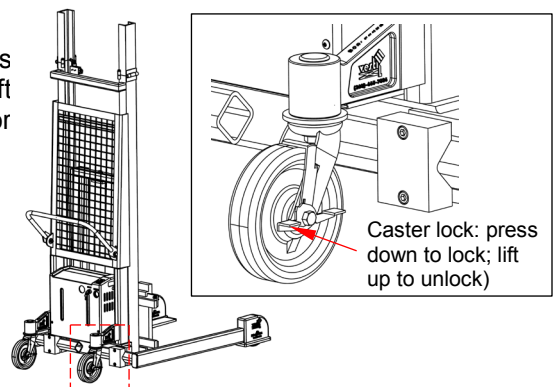

ADJUSTING THE OUTRIGGERS

[NOTE: Always unload the lifter before beginning the outrigger adjustment process.]

To adjust the outriggers:

1. Loosen the socket cap screws (13) in the leg clamp brackets.
2. Slide the outriggers through the brackets until the desired stance is achieved. The outriggers should be an equal distance from the center line. Maximum separation (measured from inside-to-inside of outriggers) must not be more than 50 1/2 inches.
3. Tighten the cap screws to 45ft-lb with a torque wrench.

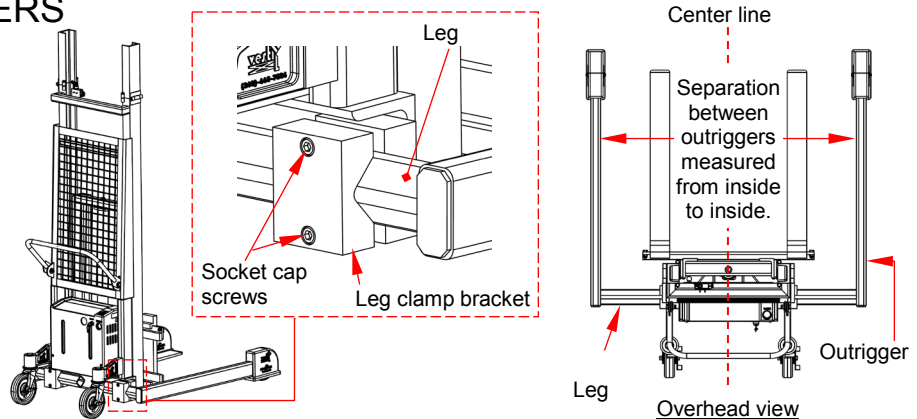

EXPLODED VIEW: AUTOSHIFTER FOOT PUMP [BILL OF MATERIALS ON NEXT PAGE]

Detail view of items 9.1-9.3

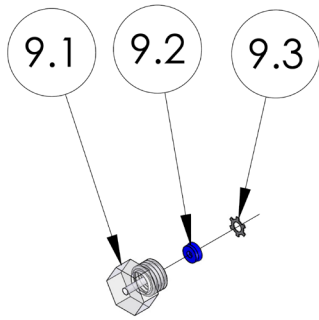

Item	Part no.	Description	Quantity
9.1	99-031-022	Release valve pin seal retainer	1
9.2	99-144-017	Seal, release valve	1
9.3	99-145-127	Star washer	1

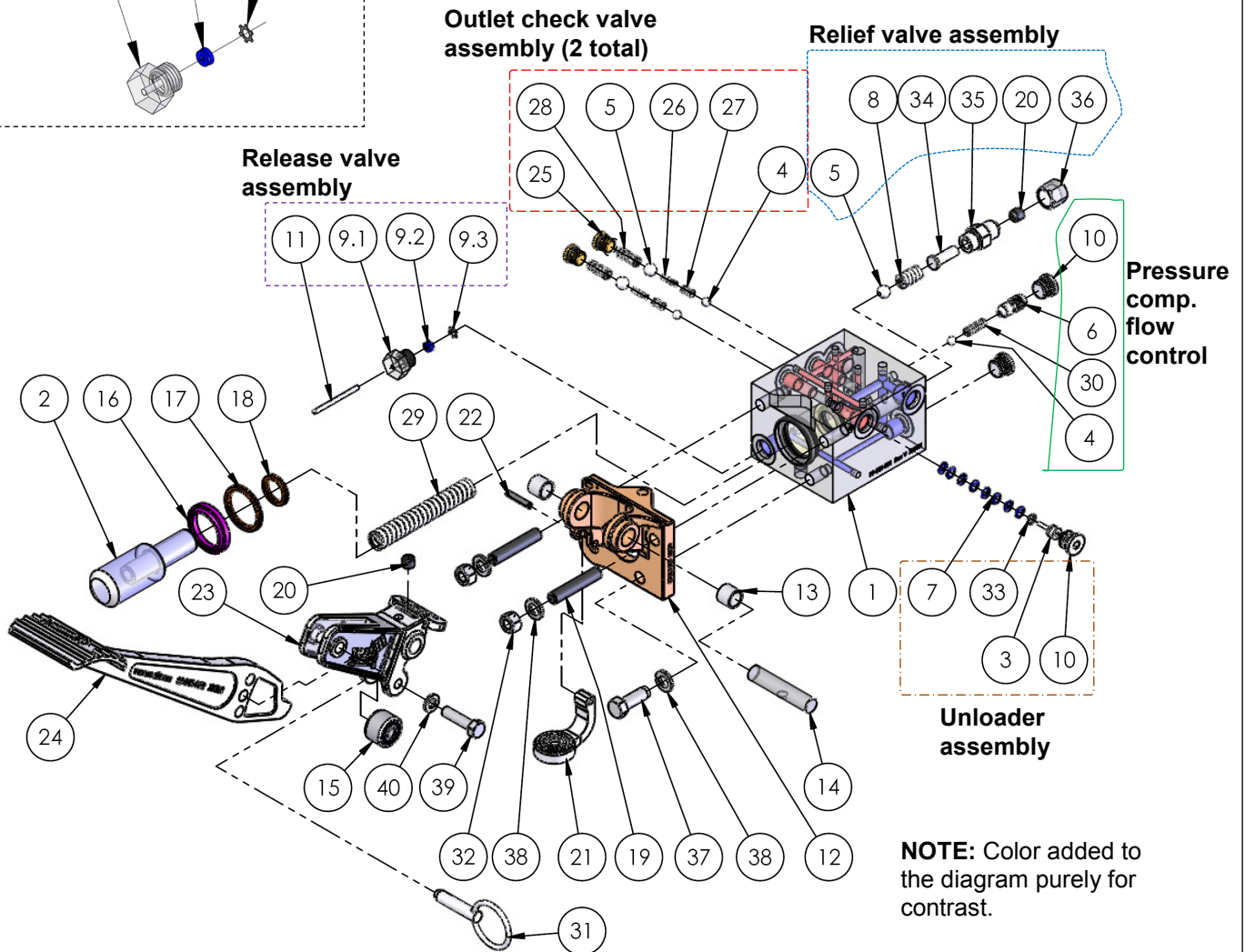

A kit of replacement seals is available for this pump. To order a seal kit, contact the Parts and Technical Service Department at http://www.vestilmfg.com/parts_info.htm. Enter part no. 99-136-013 in the "What are you looking for?" field. Alternatively, you may request replacement parts and/or service by calling (260) 665-7586. Tell the operator to connect you to the Parts Department.

Ports in pump manifold (#1 in diagram):
 The manifold has the following ports:
 • 2 pressure ports marked "P" and "FC/P";
 • 2 intake/return ports marked "T" - one is located on the rear and the other is located on the right side.
 Including 2 pressure ports and 2 intake/return ports allows the circuit configuration to be adapted to varied applications. The unused pressure and intake/return ports are each plugged with an SAE #6 port plug.

Bill of Materials: Items marked with an asterisk (*) are components of seal kit 99-136-013.

Item	Part No.	Description	Qty.	Item	Part No.	Description	Qty.
1	99-039-001	Manifold, manual pump, 1.75/0.75 bore	1	20	25537	SSS, CP, utility grade, 3/8" - 16 x 3/8"	2
2	99-041-001	Piston, pump, 1 1/4" x 3/4"	1	21	99-040-001	Lever, release pedal	1
3	99-041-002	Piston, pump, unloader	1	22	64133	Pin, spring pin, 3/16" - 1" long	1
4	99-110-007	Bearing, ball, 1/4"	3	23	99-016-017	Bracket, pedal link	1
5	99-110-006	Bearing, ball, 3/8"	3	24	99-040-002	Lever, foot pedal, 2-speed, auto-shifter	1
6	99-153-038	Flow control spool, pressure compensated, 1.0 gal.	1	25	99-116-005	MORB hollow hex plug, SAE 4	2
7	99-114-001	Washer, beveled spring washer	8	26	99-146-004	Spring, compression, inlet check	2
8	99-146-008	Spring, relief	1	27	99-146-006	Spring, compression, retainer	2
9	99-653-005	Assembly, release valve packing	1	28	99-146-005	Spring, compression, outlet check	2
9.1	99-031-022	Accessory, hydraulic, relief valve pin seal retainer	1	29	99-146-009	Spring, compression, return piston	1
*9.2	99-144-017	Seal, release valve	1	30	99-146-007	Spring, release ball	1
*9.3	99-145-127	Washer, star	1	31	99-112-049	Pin, detent ring	1
10	99-031-066	Plug, SAE #6 port	3	32	36106	Hex nut, grade A, zinc plated, 3/8" - 16	2
11	99-112-009	Pin, release pin	1	*33	99-144-019	O-ring, 1/32" inner diameter x 1 1/32" outer diameter x 1/16" CS	1
12	99-016-018	Bracket, pivot plate	1	34	99-112-050	Pin, spring guide	1
*13	01-111-013	Bushing, polygon 1/2" inner diameter x 1/2" long	2	35	99-153-070	Valve, relief	1
14	99-112-008	Pin, pivot	1	36	99-031-069	Cap, #6 JIC	1
15	20-110-003	Cam roller with seal	1	37	11105	Hex bolt, grade A, zinc plated, 3/8" - 16 x 1"	1
*16	99-031-067	Wiper, 1 1/4" inner diameter x 1 1/2" outer diameter x 3/16"	1	38	33622	Split lock washer, carbon steel, medium zinc finish, 3/8"	3
*17	99-144-018	Seal, 1 1/4" x 1/8" CS	1	39	11057	Hex bolt, grade A, zinc plated, 5/16" - 18 x 1 1/4"	1
*18	99-144-015	U-cup, 3/4" x 1.000 x 0.125"	1	40	33620	Lock washer, medium split, 5/16"	1
19	25547	Socket head set screw, black oxide finish, 3/8" - 16 x 2"	2				

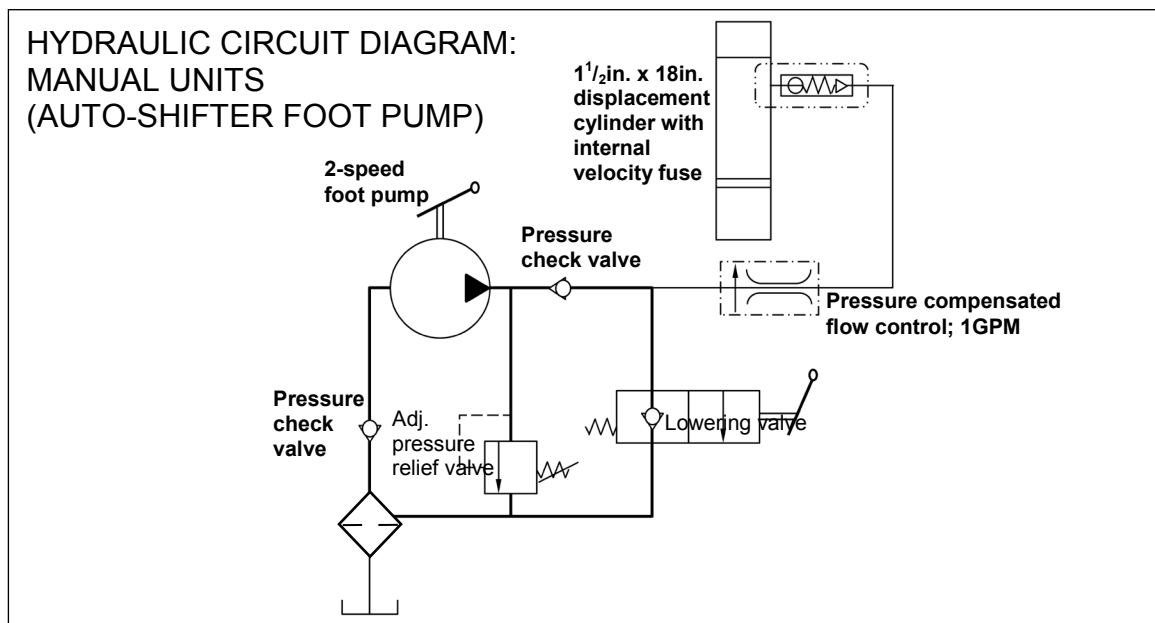

OPERATING THE LIFTER: MANUAL UNITS (AUTOSHIFTER FOOT PUMP)

Manually operated versions of this machine utilize auto-shifting, two-speed pumps. Pump speed is automatically selected based on the output pressure of the hydraulic system. For example, when the forks are unloaded, pressure in the hydraulic system is low and the pump operates in high speed mode. Each stroke of the foot pedal pumps approximately 1.2 cubic inches of oil. When weight is applied to the table, system pressure increases. At pressures in the range of 800-1000 psi the pump automatically shifts into low speed mode. In low speed mode, less effort is required to move the pedal because each stroke moves just ~0.44 cubic inches of oil.

The forks rise with each stroke of the foot pedal. However, if too much weight is applied, i.e. weight exceeding the capacity, a pressure relief valve opens and allows oil to flow back to the hydraulic reservoir rather than to the cylinder. As a result, the forks will not rise until the weight of the load is either equal to or less than the capacity (1,200 pounds).

To lower the forks, press the release pedal (item no. 21 on pp. 13-14). A pressure compensated flow control valve ensures that the fork carriage lowers at a uniform and controlled rate. Never increase the pressure relief setting more than necessary. Never exceed the pressure rating of the components in the hydraulic system.

PURGING AIR FROM THE PUMP

Air periodically becomes trapped inside the pump and has to be removed. When air is present in the hydraulic system, you might notice a spongy feel to the foot pedal while pressing it.

To remove air from the system:

1. Completely lower the forks and unload them.
2. Remove the fill plug from the oil reservoir.
3. Disconnect the hydraulic hose from the port on the cylinder and insert the free end of the hose into the fill port of the reservoir;
4. Pump the foot pedal several times and pay close attention to the stream of oil flowing into the reservoir. Pockets of air will escape as oil flows into the reservoir.
5. When you no longer see/hear air escaping, reconnect the pump to the cylinder by reattaching the hydraulic hose to the cylinder port.
6. Check all of the hydraulic lines for oil leaks.
7. Although air has been removed from the pump, air could still be trapped in the cylinder. The next procedure explains how to remove air from the *cylinder*.

PURGING AIR FROM THE CYLINDER

A bleeder screw is located at the top of the cylinder. The bleeder screw includes a hose fitting to allow attachment of a (small diameter) hose. Attach a hose to the screw to divert any oil that escapes during the bleeding process into a container for proper disposal.

To bleed air from the cylinder:

1. Completely lower the forks and unload them.
2. Gently pump the foot pedal once.
3. Carefully open the bleed screw. The pressure built in the system from pumping the pedal causes air and oil to flow out of the bleed screw. Pressure will drop as air and oil flow from the cylinder. To pressurize the system, close the bleed screw and pump the pedal once. Open the bleed screw again to allow more trapped air to escape.
4. Repeat step 3 until air is completely removed from the cylinder, i.e. only oil flows from the bleed screw.
5. Close the bleeder screw.
6. Check all of the hydraulic lines for oil leaks. Repair all leaks. Once there are no leaks, return the unit to service.

TROUBLESHOOTING: MANUAL UNITS (AUTO-SHIFTER FOOT PUMP)

Issue	Explanation	Remedy
1. Forks do not rise despite pumping pedal	<ul style="list-style-type: none"> a. Too much weight on the forks (load exceeds capacity). b. Too little oil in hydraulic system c. Pinched hydraulic hose d. Relief valve pressure setting too low 	<ul style="list-style-type: none"> a. Remove enough of load that weight of load is within capacity of lifter b. Add oil until level is within one inch of top of reservoir c. Correct as appropriate d. Increase pressure setting as necessary, but NEVER more than 3,000psi
2. A lot of force is required to pump the pedal and the forks do not rise or rise very slowly	<ul style="list-style-type: none"> e. Debris under pressure relief valve f. Debris under inlet check valve 	<ul style="list-style-type: none"> e. Remove, disassemble, clean (with mineral spirits or kerosene), reassemble and reinstall pressure relief valve assemblies. f. Remove, disassemble, clean (with mineral spirits or kerosene), reassemble and reinstall check valve assemblies.
3. Forks rise only when unloaded or pedal pumped rapidly; I can pump the pedal but the forks do not move.	<ul style="list-style-type: none"> g. Pump is air locked h. Debris on seat of inlet check valve i. Pressure setting of relief valve needs adjustment j. Debris on seat of relief valve 	<ul style="list-style-type: none"> g. Remove air from the pump. See Purging air from the pump on p. 15. h. Remove inlet check valve and clean debris from valve seat (the bottom of the cavity in pump body that valve fits into). i. Increase pressure setting as necessary, but NEVER more than 3,000psi. j. Remove relief valve and clean debris from valve seat in pump body.
4. Forks rise during the down stroke of the pedal, but lower during the upstroke.	<ul style="list-style-type: none"> k. Outlet check valve stuck in open position 	<ul style="list-style-type: none"> k. Remove, disassemble, clean (with mineral spirits or kerosene), reassemble, and reinstall outlet check valve assemblies.
5. Forks rise and maintain elevation, but I have to pump the pedal a million times	<ul style="list-style-type: none"> l. Autoshifter valve stuck in closed/deactivated position (piston out). 	<ul style="list-style-type: none"> l. Remove port plug from port marked "UL" on pump body. Remove piston. Inspect piston and springs.
6. Forks rise very slowly	<ul style="list-style-type: none"> m. Autoshifter valve stuck in open/activated position (piston in) 	<ul style="list-style-type: none"> m. Remove port plug from port marked "UL" (on pump body); then remove piston. Inspect piston and springs
7. Pump pedal feels spongy or forks rise in jerks	<ul style="list-style-type: none"> n. Debris interfering with carriage rollers o. Oil level is low p. Air present in pump and/or cylinders 	<ul style="list-style-type: none"> n. Clean the inside of the mast and surfaces of rollers as necessary o. Add oil until level is within 1in. of top of reservoir. p. Purge air. See Purging air from the pump and Purging air from the cylinder on p. 15.
8. Forks lower very slowly	<ul style="list-style-type: none"> q. Flow control valve obstructed 	<ul style="list-style-type: none"> q. Remove valve and inspect for debris or non-operating spool
9. Forks lower too rapidly	<ul style="list-style-type: none"> r. Flow control valve obstructed or not moving freely 	<ul style="list-style-type: none"> r. Remove valve and inspect for debris or non-operating spool
10. Forks rise part way and then stop	<ul style="list-style-type: none"> s. Air trapped in small pump chamber 	<ul style="list-style-type: none"> s. Perform Purging air from the pump on p. 15.

HYDRAULIC CIRCUIT DIAGRAM: ELECTRICALLY POWERED UNITS

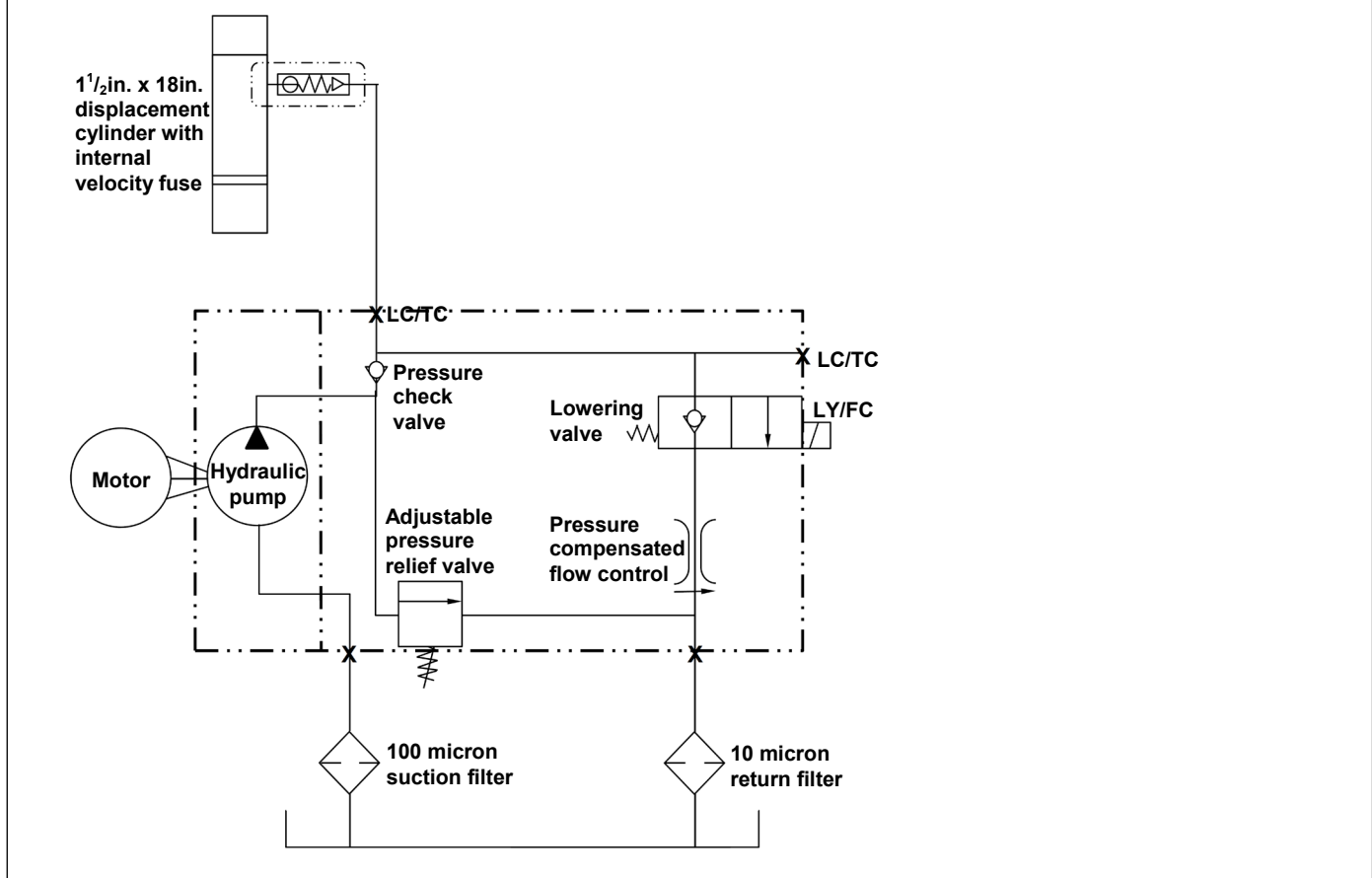

OPERATING THE LIFTER: ELECTRIC UNITS (MODULAR POWER UNIT)

If your unit was manufactured on or after Dec. 1, 2018, see the [NOTE](#) in the Table of Contents on the cover page.

Pushbutton controls are standard equipment on PMPS series pallet handlers, i.e. a handheld controller as well as control buttons on the housing of the modular power unit. To raise or lower the fork carriage, first make sure that power is turned on (on/off switch points to ON); then press either the RAISE or LOWER button. When either button is released, the carriage will maintain position until the RAISE or LOWER button is pressed.

OPERATION

To raise the forks, press the RAISE button on the pushbutton controller. This starts the electric motor which turns the hydraulic pump. Oil from the reservoir (inside the modular power unit) flows through the suction filter and into the pump. The pump delivers pressurized oil to the hydraulic cylinder through a check valve. The check valve allows oil to flow only in one direction, i.e. to the cylinders, and prevents oil from flowing back into the pump circuit when the pump stops. This traps oil in the cylinder, which allows the forks to maintain elevation after the control button is released.

If a load exceeds the capacity of the lifter, pressure will build up in the circuit between the pump and the cylinders when the RAISE button is pressed. Pressure forces the relief valve to unseat which in turn allows oil to circulate back to the reservoir instead of to the cylinder. This pressure relief mechanism prevents damage to the hydraulic system.

To lower the forks, press the LOWER button. This energizes the lowering solenoid valve coil, which unseats the poppet valve and allows oil to return to the reservoir from the cylinders through the pressure-compensated flow control valve. Releasing the LOWER button de-energizes the solenoid and closes the valve poppet. The poppet valve and check valve together prevent oil from returning to the reservoir and cause the cylinders to stop retracting. The forks remain elevated until the operator presses a button on the pushbutton controller again.

LOWERING SOLENOID VALVE

The pallet handler is equipped with a cartridge lowering valve. If a malfunction occurs while lowering the fork carriage (item no. 6 on [p. 4 & 5](#); item no. 5 on [p. 6](#)), refer to the solutions presented in [Troubleshooting](#) on p. 21. If a malfunction of this valve occurs, clean it by applying the following procedure:

1. Completely lower the forks.
2. Use a thin tool to press the poppet in from the bottom and open the valve.
3. Repeat several times while immersing the valve in kerosene or mineral spirits; then blow dry the cleaned valve.
4. Blow compressed air through the valve while holding the valve open as described in step 2.

5. Inspect the O-rings and the PTFE washer (polytetrafluoroethylene). If either component is damaged (for example, torn or cut) replace it.
6. Reinstall the valve. The valve should be tightened to approximately 20 ft.-lb. of torque.

VELOCITY FUSE

There is a brass velocity fuse with a stainless steel spring in the base of each cylinder. If a fitting leaks or a hose is ruptured, the platform lowers more rapidly. If the rate of descent exceeds the preset speed, the Velocity Fuse will shut. As long as the fuse is shut oil cannot flow and the forks will remain stationary until pressure is reestablished. This safety feature reduces the possibility of personal injury or damage to the pallet handler (or load) that could result if the forks suddenly fall.

If air enters the hydraulic system, the velocity fuse might activate although no failure occurs. To reset the velocity fuse, jog the pump by pressing the RAISE button and immediately releasing it. Once the velocity fuse is reset, lower the forks and remove the load. Then, cycle the carriage (raise the forks all the way to the top of the mast and back down) several times to purge air from the system.

BLEEDING AIR FROM THE HYDRAULIC CIRCUIT

If the forks descend very slowly or fail to lower at all, air probably is trapped in the hydraulic circuit and must be bled from the system. The LL-PMPS has a "bleeder" screw at the top of the cylinder. To bleed air from the hydraulic circuit, follow these directions.

1. Completely unload the forks.
2. Loosen the bleeder screw at the top of the cylinder by turning it approximately $1/4$ to $1/2$ turn to allow trapped air to escape. Jog the motor (press and release the RAISE button several times) to push air out of the system.
3. When the cylinder is free of air, only clear hydraulic fluid will flow from the bleeder screw opening. When you observe only oil flowing from the bleeder, retighten the screw.

BATTERY CHARGER OPERATION (DC UNITS ONLY)

⚠WARNING

Working on lead-acid batteries is dangerous. Batteries contain sulfuric acid and produce explosive gases. A battery explosion could result in loss of eyesight or serious burns.

- DO NOT smoke near the battery or expose the battery to a spark or flame.
- ONLY charge batteries in dry, well-ventilated locations.
- DO NOT lay tools or metallic items on top of a battery. NEVER touch both terminals simultaneously! Remove personal items such as rings, bracelets, necklaces, and watches. A battery can produce enough voltage to weld jewelry to metal.
- Always have plenty of fresh water and soap nearby in case contact with battery acid occurs.
- Operating the battery with low voltage can cause premature motor contact failure.
- The charger has an external ground wire (small green wire). During installation, the charger must be grounded to the lifter. Be sure this wire is always connected to the chassis, frame, or other metallic surface considered to be ground.
- Confirm that all battery connections are sound and clean. Remove accumulated deposits from the terminals.
- Replace defective electrical cords/wires immediately.
- DO NOT use the charger if the flanged inlet is damaged.
- DO NOT connect the charger to a damaged extension cord.

Every DC powered LL-PMPS is equipped with an onboard battery charger with a flanged electrical inlet. The charger is current limited and will not exceed its rated output even if loads are placed on the battery while it is charging. The charger fuse will blow if it is connected in reverse polarity.

To charge the battery:

- 1.) Plug the charger into a 115VAC, 60 Hz receptacle by connecting the flanged inlet on the charger to an extension cord. Plug the other end of the cord into a wall socket. Use a short, thick extension cord.
- 2.) When properly connected, the charge LED will indicate the status of charge current flowing to the battery.
 - If only the red LED is on, the charger is providing full output to the battery.
 - If both the red and green LED's are on, the charger is topping off the battery.
 - When only the green LED is on, the unit is providing a "float" (maintenance) charge.
 - DO NOT leave the charger on for long periods after the battery is fully charged.
- 3.) Unplug the charger before using the lifter. Failure to do so could cause damage to cords, receptacles, etc.

EXTERNAL FEATURES OF MPU

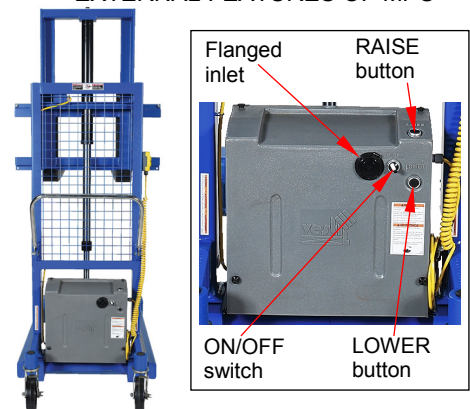

TROUBLESHOOTING

- 1) Make sure all battery connections sound.
- 2) Confirm that the AC power source (e.g. wall socket) is supplying power.
- 3) Examine the fuse (see p. 8). Replace only with a fuse having the same rating as the original.
- 4) Determine battery condition. It may take some time before current begins to flow through a highly sulfated battery.

RECORD OF SATISFACTORY CONDITION

Record the condition of the lifter before putting it into regular service. Thoroughly photograph the machine from multiple angles. Include close range photos of all labeling, the handle, casters/wheels, the cylinder, cylinder attachment points and attachment hardware (pins, bolts, nuts, etc.), leg clamp brackets, and modular power unit (MPU). Remove the cover from the MPU and photograph the internal components. Cycle the carriage up and down. Describe the motion of the carriage, e.g. smooth and uniform at a rate of approximately ___ in/s. Describe sounds heard as the unit operates. Collate all photographs and writings into a single file. Mark the file appropriately to identify it. This record establishes satisfactory condition of the unit. Compare the findings of all inspections to this record to determine whether the unit is in satisfactory condition. If the machine is not in satisfactory condition, repair it before returning it to service. Purely cosmetic changes, like damaged paint/powdercoat, do not constitute changes from satisfactory condition. However, touchup paint should be applied to all affected areas as soon as cosmetic damage occurs to prevent rusting and corrosion.

INSPECTIONS & MAINTENANCE

NOTICE

Regular maintenance is essential to keep this product in nominal condition. Before beginning maintenance, completely unload the forks and lower them.

- Relieve hydraulic pressure whenever the unit is not in use by fully lowering the forks.
- Keep the product clean & dry. Lubricate moving parts at least once per month.
- ONLY use manufacturer-approved replacement parts. Vestil is not responsible for issues or malfunctions that result from the use of unapproved replacement parts.
- ONLY use ISO AW-32 hydraulic fluid or its equal in the hydraulic system. Do not use brake fluid or jack oils in the hydraulic system. If oil is needed, use an anti-wear hydraulic oil with a viscosity grade of 150 SUS at 100°F, (ISO 32 cSt @ 40°C), or Dexron transmission fluid.
- Contact the manufacturer for MSDS information.

Inspections:

(A) Before Each Use--Inspect the following:

1. Wiring: inspect the electrical wiring for cuts or frays;
2. Casters: examine the casters and confirm normal operating condition;
3. Hydraulic hoses: check for pinches, punctures, or loose connections;
4. Structure: inspect the base and frame for deformations and cracked welds;
5. Forks; carriage; mast: cycle the forks up and down. Listen and watch for unusual noise, motion (e.g. binding).
6. Pushbutton controller: inspect the controller and look for damage that exposes

(B) Monthly Inspections--at least once per month check the following:

1. Oil level. Lower the forks completely and unload them. Oil should be 1" - 1½" below the top of the tank/reservoir. Add oil as necessary. Look for oil leaking from hoses, the cylinder, or the reservoir. See [Troubleshooting](#) (p. 20) and correct as appropriate.
2. Battery: check the water level in the battery. (*DC models only*)
3. Clevis and pivot points: inspect for excessive wear.
4. Hydraulic system, wiring, and pushbutton control: Check for worn or damaged hydraulic hoses, electrical wires, and cords. Repair as necessary.
5. Carriage rollers (see diagrams on [p. 4, 5, & 6](#)): check rollers and retaining hardware for normal condition.
6. Forks, carriage and mast: cycle the forks up (to the top of the mast) and back down while listening and watching for unusual noise, motion, or binding.
7. Labels: Confirm that all labels are in place and easily readable. See [Labeling Diagram](#) on p. 21.
8. Surfaces: remove dirt and debris.

(C) Yearly Inspection

Hydraulic oil should be changed at least once a year or sooner if the oil darkens or becomes gritty. Flush the reservoir before refilling. Similarly, if the oil appears milky, water is present and the oil should be changed.

Maintenance: ANSI/ITSDF standard B56.10 describes recommended maintenance procedures. The following steps should be utilized in conjunction with those recommendations.

1. Tag the unit, "Out of Service."
2. Perform a "Before each use" inspection. If deformity, corrosion, rusting, or excessive wear of structural members is present, DO NOT use the pallet handler. Contact Vestil for instructions. If the carriage does not move smoothly or makes noise as it moves up or down the mast, apply a silicon wax or silicon spray to the inside of the mast frame.
3. Remove any dirt or other matter from the forks and other surfaces.
4. Perform all other necessary adjustments and/or repairs. DO NOT modify the lifter.
5. Make a dated record of the repairs, adjustments and/or replacements.

REPLACEMENT PARTS

Only use manufacturer-approved replacement parts to repair this machine. To order parts for your equipment, please contact the [Parts Department](#). In any correspondence with the factory please include the Serial Number which is inscribed on the nameplate of the equipment. Use only the part numbers provided in this Owner's Manual. When ordering parts for AC power units, please be prepared with the motor phase and voltage of the equipment.

TROUBLESHOOTING: ELECTRIC UNITS (MODULAR POWER UNIT)

Contact [Technical Service](#) for assistance whenever necessary.

Issue	Possible Cause	Remedy
1. Forks don't rise and motor does not run.	a. Low battery voltage. (Check light) b. All chassis connections to negative post of battery not made well.	a. Recharge battery b. Check and tighten or clean connections if necessary.
2. Forks don't rise when motor runs.	c. Voltage at motor terminals might be too low to run pump at existing load. d. Fluid level in reservoir is low. e. Load exceeds capacity requirements. Relief valve is allowing hydraulic fluid to flow back into the reservoir. f. Suction filter is clogged, starving pump. g. Suction line fittings are loose allowing air to enter. h. Filter/Breather cap on tank is clogged. i. Lowering solenoid valve might be energized by faulty wiring or might be stuck open. j. Hydraulic pump not operating.	c. Measure voltage at motor terminals (as near as possible) while pump runs under load. Check for loose wiring connections. d. Add fluid. See Monthly inspections on p. 19 for proper fluid level. e. DO NOT CHANGE RELIEF VALVE SETTING. Instead, reduce the load to rated capacity. f. Remove filter and clean. g. Inspect all fittings for proper tightness. h. Remove cap and clean. i. Remove lowering solenoid valve. Check and clean. Refer to Lowering Solenoid Valve on pp. 17-18. j. Disconnect hydraulic line from power unit. Put pressure line in a large container and operate the pump. If no output, check the pump motor coupling and correct as appropriate. If pump is worn, contact factory for replacement parts.
3. Forks rise really slowly.	k. Foreign material stuck in lowering solenoid valve causing fluid to flow back into the reservoir. l. Foreign material clogging suction filter or breather cap, or a hose is pinched. m. Low motor voltage. n. Unit overloaded. o. Inoperative pump.	k. Lower the forks. Remove the lowering solenoid valve and clean. Refer to pp. 17-18. l. Correct as appropriate. See also, 2(f), (h). m. See 1(b) n. See 2(e) o. See 2(j)
4. Motor labors or is extremely hot.	p. Battery voltage too low. q. Oil starvation causing pump to bind & overheat. [NOTE: pump can be permanently damaged.] r. Binding cylinder.	p. See 1(b) q. See 2(d), (f), (g), (h), (j) r. Align cylinder correctly.
5. "Spongy" forks—forks rise in jerks or are spongy when elevated.	s. Fluid starvation. t. Air in system.	s. See 2 (d), (f), (g), (j) t. See Bleeding air from the hydraulic circuit , p. 18.
6. Unit lowers very slowly when loaded.	u. Lowering solenoid valve filter screen clogged. v. Pinched tube or hose. w. Foreign material in flow control valve. x. Binding cylinders. y. Foreign material in velocity fuse.	u. Remove lowering solenoid valve and clean filter screen. v. Correct as appropriate. w. Remove and clean flow control valve. Refer to Hydraulic System Diagram on p. 17. x. Align cylinders correctly. y. Remove and clean velocity fuse. Refer to Hydraulic Circuit Diagram on p. 17.
7. Forks lower too quickly.	z. Foreign material stuck in flow control valve. (In this case, carriage initially lowers at a normal rate but accelerates as the carriage descends).	z. Remove flow control valve from the valve block and clean. Refer to Hydraulic Circuit Diagram on p. 17.
8. Forks rise but slowly fall on their own.	aa. Lowering solenoid valve may be incorrectly wired or is stuck open bb. Check valve stuck open. cc. Leaking hoses, fittings, pipes. dd. Cylinder packing is worn or damaged.	aa. See 3 (k). bb. Remove and clean check valve. See p. 8 & 11. cc. See 2 (c). dd. Replace packing. Contact factory.
9. Forks rise but do not lower.	ee. Incorrect lowering solenoid valve wiring. ff. Lowering solenoid valve is stuck. gg. Faulty lowering solenoid coil. hh. Binding cylinders. ii. Air present in the hydraulic system causing the velocity fuse to activate	ee. Correct per diagram (p. 17). ff. Lightly tap down the solenoid coil body to seat it properly. (DO NOT hit coil hard as it will permanently damage the internal system. DO NOT remove the solenoid valve from the block because the carriage will descend dangerously quickly.) gg. Remove and replace. DO NOT remove the lowering solenoid valve from the block because the forks will lower in an uncontrolled manner. hh. See 4 (r). ii. Unlock by pressurizing the hydraulic system. Press UP button.

LABELING DIAGRAM

The unit should be labeled as shown in the diagram. However, label content and location are subject to change so your product might not be labeled exactly as shown. Replace all labels that are damaged, missing, or not easily readable (e.g. faded). To order replacement labels, contact the technical service and parts department online at http://www.vestilmfg.com/parts_info.htm. Alternatively, you may request replacement parts and/or service by calling (260) 665-7586 and asking the operator to connect you to the **Parts Department**.

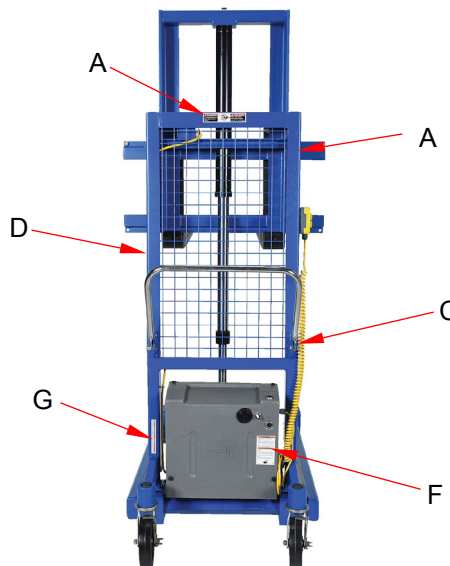
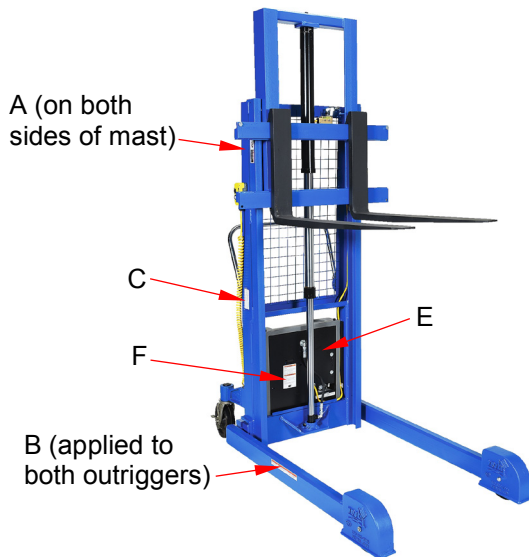

A: Label 824

⚠ DANGER		⚠ PELIGRO
To avoid bodily injury, stand clear while in motion.		Para evitar daños, manténgase alejado cuando en movimiento

B: Label 643

⚠ WARNING	⚠ ADVERTENCIA	⚠ AVERTISSEMENT
KEEP CLEAR OF PINCH POINT	MANTÉNGASE ALEJADO DEL PUNTO DE CORTE	SE TENIR À DISTANCE DU POINT DE PINCEMENT
<small>VESTIL MANUFACTURING CORPORATION • Phone (260) 665-7586 • Fax (260) 665-1339 • sales@vestil.com • www.vestil.com</small>		

C: Label 287

MODEL/MODEL/MODELE	_____
STATIC CAPACITY (evenly distributed)	_____ lbs.
LA CAPACIDAD CONSTANTE (distribuida uniformemente)	_____ kgs.
CAPACITÉ STATIQUE (distribuée régulièrement)	_____ kgs.
SERIAL/SERIE/SÉRIE	_____

287 REV 01/12

E: Label 206 (inside MPU on oil tank)

ISO 32 / 150 SUS
HYDRAULIC OIL OR NON-SYNTHETIC TRANSMISSION FLUID
ACEITE HIDRAULICO O LIQUIDOS DE TRANSMISION NO SINTETICOS
HUILE OU LIQUIDE HYDRAULIQUE NON-SYNTHEIQUE
<small>Rev. 10/03</small>
<small>VESTIL MANUFACTURING CORPORATION • Phone (260) 665-7586 • www.vestil.com</small>

F: Label 295 (on MPU cover)

⚠ WARNING
Enclosed battery contains hazardous chemicals.
DO NOT handle enclosed battery UNLESS wearing eye protection and other appropriate personal protective equipment.
DO NOT directly contact skin with battery.
DO NOT expose to sparks or extreme heat; battery contains explosive gases.
⚠ ADVERTENCIA
La batería incluida contiene materiales peligrosos.
NO use la batería incluida A NO SER que lleve protección de ojos y otros equipos de protección apropiados para el personal.
NO tenga contacto directo en la piel con la batería.
NO exponga a destellos o a calor excesivo, la batería contiene gases explosivos.

<small>295 rev 01/11</small>

D: Label 527

⚠ WARNING
Only trained, authorized persons should operate this device. Improper operation might result in serious personal injuries sustained by the truck operator and/or bystanders. Operators must observe the following safety-enhancing practices:
<ul style="list-style-type: none"> • BEFORE operating, inspect mast, carriage, forks/deck, cable/chain, wheels, and brakes for damage. DO NOT use if damaged. • ALWAYS walk travel path before using truck to identify hazards: <ul style="list-style-type: none"> 3 DO NOT contact electrical lines or overhead objects with device or load; 3 DO NOT travel up/down inclines if an alternate route is available; 3 DO NOT travel over debris. • ONLY travel with forks/deck in lowest position appropriate for conditions. • ALWAYS center and evenly distribute loads on forks/deck. • ALWAYS secure load to forks/deck. • ONLY drive or operate truck functions from operator position. • DO NOT exceed maximum rated load (capacity). • DO NOT allow people to ride on device. • DO NOT lift loads over people; DO NOT permit people to walk beneath the forks/deck when raised (loaded or unloaded). • DO NOT leave unattended UNTIL fully lowered AND unloaded. • DO NOT modify device in any way.
⚠ ADVERTENCIA
Solo personas entrenadas y autorizadas deben operar este equipo. La operación inadecuada podría resultar en daños serios al operario del camión y/o a los transeúntes. Los operarios deben observar y seguir las siguientes prácticas de seguridad:
<ul style="list-style-type: none"> • ANTES de usar, inspeccione el mástil, el equipo, las horquillas/plataforma, cable/cadena, ruedas y frenos por daños. NO use si se observan daños. • SIEMPRE camine el trayecto de viaje antes de usar el camión para identificar riesgos: <ul style="list-style-type: none"> 3 NO toque las líneas eléctricas u objetos altos con el dispositivo o la carga; 3 NO viaje en inclinaciones de subida y bajada si hay otra ruta alternativa; 3 NO viaje sobre desechos. • SOLO viaje con las horquillas/plataforma en la posición de descenso más apropiada para las condiciones. • SIEMPRE centre y distribuya las cargas uniformemente en las horquillas/plataforma • SIEMPRE asegure la carga a las horquillas/plataforma. • SOLO conduzca u opere las funciones del camión desde la posición del operario. • NO exceda la capacidad máxima tasada de carga. • NO permita que la gente viaje en el equipo. • NO eleve las cargas sobre la gente; NO permita que la gente camine debajo de las horquillas/plataforma cuando este elevada (con carga o sin carga). • NO deje el equipo desatendido HASTA que este completamente cargado Y descargado. • NO modifique el equipo de ninguna manera.
<small>527 • Rev 11/09</small>

G: Label 212

⚠ WARNING	⚠ ADVERTENCIA	⚠ AVERTISSEMENT
LOCK CASTER when loading and unloading	PONGA EL FRENO de la rueda cuando se cargue y descargue	VERROUILLER LA ROULETTE en chargeant et decharger
<small>Vestil Manufacturing Corporation • Angola, Indiana USA • Phone (260) 665-7586 • www.vestil.com</small>		
<small>212 Rev 09/08</small>		

LIMITED WARRANTY

Vestil Manufacturing Corporation (“Vestil”) warrants this product to be free of defects in material and workmanship during the warranty period. Our warranty obligation is to provide a replacement for a defective, original part covered by the warranty after we receive a proper request from the Warrantee (you) for warranty service.

Who may request service?

Only a warrantee may request service. You are a warrantee if you purchased the product from Vestil or from an authorized distributor AND Vestil has been fully paid.

Definition of “original part”?

An original part is a part used to make the product as shipped to the Warrantee.

What is a “proper request”?

A request for warranty service is proper if Vestil receives: 1) a photocopy of the Customer Invoice that displays the shipping date; AND 2) a written request for warranty service including your name and phone number. Send requests by one of the following methods:

US Mail	Fax	Email
Vestil Manufacturing Corporation 2999 North Wayne Street, PO Box 507 Angola, IN 46703	(260) 665-1339 Phone (260) 665-7586	info@vestil.com Enter “Warranty service request” in subject field.

In the written request, list the parts believed to be defective and include the address where replacements should be delivered. After Vestil receives your request for warranty service, an authorized representative will contact you to determine whether your claim is covered by the warranty. Before providing warranty service, Vestil will require you to send the entire product, or just the defective part (or parts), to its facility in Angola, IN.

What is covered under the warranty?

The warranty covers defects in the following original, dynamic parts: motors, hydraulic pumps, motor controllers, and cylinders. It also covers defects in original parts that wear under normal usage conditions (“wearing parts”), such as bearings, hoses, wheels, seals, brushes, and batteries.

How long is the warranty period?

The warranty period for original dynamic components is 1 year. For wearing parts, the warranty period is 90 days. Both warranty periods begin on the date Vestil ships the product to the Warrantee. If the product was purchased from an authorized distributor, the periods begin when the distributor ships the product. Vestil may, at its sole discretion, extend a warranty period for products shipped from authorized distributors by up to 30 days to account for shipping time.

If a defective part is covered by the warranty, what will Vestil do to correct the problem?

Vestil will provide an appropriate replacement for any *covered* part. An authorized representative of Vestil will contact you to discuss your claim.

What is not covered by the warranty?

The Warrantee (you) are responsible for paying labor costs and freight costs to return the product to Vestil for warranty service.

Events that automatically void this Limited Warranty.

- Misuse;
- Negligent assembly, installation, operation or repair;
- Installation/use in corrosive environments;
- Inadequate or improper maintenance;
- Damage sustained during shipping;
- Collisions or other accidents that damage the product;
- Unauthorized modifications: Do not modify the product IN ANY WAY without first receiving written authorization from Vestil.

Do any other warranties apply to the product?

Vestil Manufacturing Corp. makes no other express warranties. All implied warranties are disclaimed to the extent allowed by law. Any implied warranty not disclaimed is limited in scope to the terms of this Limited Warranty. Vestil makes no warranty or representation that this product complies with any state or local design, performance, or safety code or standard. Noncompliance with any such code or standard is not a defect in material or workmanship.

